

ACCESSORIES & MAINTENANCE PARTS

Features, benefits and specifications





CUSTOMIZE YOUR EXPERIENCE

Genuine Volvo Penta Accessories and Propellers are developed to help you customize your Volvo Penta and to make your boating experience greater and even more enjoyable.

Our focus on easy, comfortable and fun boating is reflected in our wide range, making it easier than ever to add that little extra. With regular maintenance and the use of Genuine Volvo Penta Parts you also ensure your engine runs safely and is well prepared for your adventures.

Your Volvo Penta dealer is always ready to provide expertise and service so you can focus on what's most important — enjoying your time on the water.





Find your dealer

Visit www.volvopenta.com/dealerlocator or download our app to search among our 3,500 dealers worldwide.



Double your warranty

Genuine Volvo Penta parts and accessories are covered by our standard 12 month warranty. Have them supplied and installed by an authorized Volvo Penta dealer and we'll extend your warranty to 24 months — including the labor. Consult your nearest dealer for more details.

CONTENT

HIGHLIGHTS	4
EASY CONNECT	6
EASY BOATING FEATURES	8
DRIVER INTERFACE	10
Controls	11
Displays	18
Instruments	20
Steering	28
BOAT TRIM SYSTEM	31
ENGINE ACCESSORIES	32
Fuel supply	33
Exhaust system	38
Cooling system	40
Power takeoff	45
Electrical supply	46
Transmission	48
Silent Shift	50
Sound absorbent panels	51
Air heater	52
Extended Coverage	53
Repowering kits	54
PROPELLERS	58
Duoprop propellers for Aquamatic	59
Single propellers for Aquamatic	64
Propellers for Volvo Penta IPS	66
Folding propellers for saildrive and shaft	68
Fixed propellers for saildrive	72
Anodes	73
ACTIVE CORROSION PROTECTION	74
EXCHANGE COMPONENTS	76
MAINTENANCE	77
Oils, lubricants and coolants	78
Paints	84
Maintenance kits	85
Maintenance parts	86

HIGHLIGHTS



EASY CONNECT WITH YOUR SMART DEVICES

We have added more exciting features that improves your connected life on board. The latest update includes a new and improved look of the app, access to navigation charts from Navionics for further precision and a filter function that makes it easier to search among past trips. Volvo Penta Easy Connect is now also available for boats with three or four engines.

PAGE 6



SILENT AND SMOOTH SHIFTING

The Volvo Penta Silent Shift technology for Aquamatic sterndrives provides silent and smooth shifting. This technology is now available for D3 and gasoline engines. All it takes is changing out the upper gear unit on the existing drive.

PAGE 50



STAINLESS STEEL DUOPROP PROPELLERS – FOR DPH DRIVES

The type H propellers - developed for the new generation of D4 and D6 engines - are now also available for DPH drives. Made of high-strength stainless steel alloy for excellent durability and strength. The optional line cutter is easy to install and provides additional protection for your drive.

PAGE 59



ACTIVE CORROSION PROTECTION FOR VOLVO PENTA IPS

The new Active Corrosion Protection for Volvo Penta IPS has up to 30% higher protection capacity compared to the previous version. The system provides easier ownership and enhanced corrosion protection for your drives compared to using conventional sacrificial anodes. Full system integration means you can see the protection status at helm.

PAGE 74

VOLVO PENTA EASY CONNECT



Volvo Penta Easy Connect gives you a dashboard-style overview of boat and engine data, route information, and more – via Bluetooth®, directly on your smart devices. All you need is the Easy Connect Interface connected to your engine, and the Easy Connect app installed on your tablet or smartphone. The

functions also make it an ideal complement to the mounted instruments at the helm. But the experience doesn't just stay onboard. You can easily access saved routes and boat data from home – reliving the moments, or plan for your next trip.



Instant data access

Easy Connect provides instant access to engine and boat data in an easy, intuitive interface. With the Map View, you can check your current position and the route you have traveled. As an option, you can use navigation charts from Navionics⁷ for further precision. Routes and boat data are stored within the app, and can later be accessed for proactive usage like planning future trips.

Interact with your Volvo Penta dealer ^{4) 5)}

Easy Connect makes it possible to share diagnostic trouble codes with your selected Volvo Penta dealer, including; serial number and engine hours. A useful function when booking a service or inspection – allowing your dealer to prepare service and help more efficiently.

Easy installed interface

To get started, the Easy Connect interface plugs directly into the multi-link at the helm station, or into the engine harness on non-EVC gasoline engines.

NMEA functionality

The Easy Connect interface includes NMEA2000 functionality. This means it can also be connected to an existing NMEA network within the boat. This enables you to access additional data from i.e. speed and depth sensors.

In addition, the Easy Connect interface can be used to convert engine data into NMEA2000 compatible chart plotters/multi-function displays onboard.

Compatibility

Easy Connect is available for the following engines in single and twin installations:

- D1/D2 engines with MDI
- Non-EVC gasoline engines from model year 2006

Easy Connect is available for the following engines in single, twin, triple and quadruple installations:

- Diesel and gasoline engines with EVC (except D3 and gasoline engines produced before 2007 with EVC-MC A/B)

The application is available for Apple devices with iOS 10 and later. For Android devices, the operating system version must be 5.0 or later with Bluetooth[®] 4.2.

Please note that certain functions and features are not available for all engine types. For more information, visit www.volvopenta.com/easyconnect.



On board (connected)

When on board, Easy Connect provides a complete view of the boat's vital information in real time. Switch between different menu screens, showing boat speed, engine speed, maps etc. and share your experiences on social media.

Featured data within the app

The Easy Connect app is capable of showing data provided by your engine, as well as information from additional sensors and functionality installed in your boat such as:

Engine and boat data	
Engine speed	Battery voltage
Engine hours	Warnings and alarms
Oil pressure ⁶⁾	Coolant temperature
Diagnostic trouble codes ⁵⁾	Boat speed ³⁾
Depth ²⁾	Rudder position ^{6) 7)}
Fuel tank level ^{1) 2)}	Drive trim (Aquamatic) ⁹⁾

With Trip computer software (EVC)

Average fuel economy ²⁾	Trip distance
Distance to empty ²⁾	Fuel used
Fuel economy ²⁾	Fuel rate
Time to empty ²⁾	

Additional features

Journeys ³⁾	Share journeys ⁴⁾
Share engine data with your dealer ^{4) 5)}	Navigation charts ⁷⁾

¹⁾ Require EVC ²⁾ Require additional sensors ³⁾ Require additional sensors or mobile device GPS ⁴⁾ Sharing function requires an internet connection ⁵⁾ Not available for D1/D2 and engines with EVC produced before 2009 (available from EVC-C3) ⁶⁾ Not D1/D2 ⁷⁾ Require Navionics account.

Easy Connect interface kits

Part no	Interface kit
23870793	D1 and D2 engines with MDI*
23870793	Diesel and gasoline engines with EVC
23870794	Non-EVC gasoline engines MY 2006 and later*
Adapter cable is required for the engines listed below:	
23789701	Adapter cable, diesel engines with EVC-A
3883170	Adapter cable, non-EVC gasoline MY2006-2008

* Order two interface kits for twin installations.

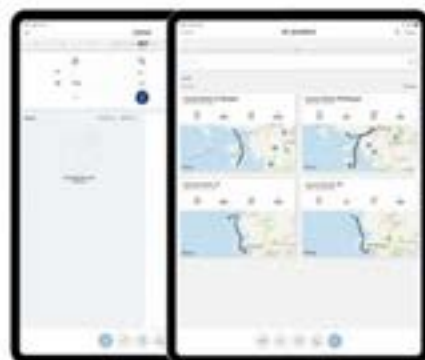

At home (not connected)

Easy Connect stores your past journeys so that you can recreate them and share on social media. You can also access an overview of key data such as fuel tank level and engine hours, and e-mail engine status to your Volvo Penta dealer.

EASY BOATING FEATURES

Volvo Penta EVC (Electronic Vessel Control) connects the engine, transmission, instruments and easy boating features in one system based on CAN-bus technology. The result is enhanced integration, easier installation and access to a wide range of smart features for easier, safer and more enjoyable boating. Welcome to a world of possibilities!



Trip computer

Get trip computer functionality with information about fuel consumption, distance to empty, trip time and much more for optimizing your boat's performance.



Cruise control

With fingertip control of your engine rpm, you can fine-tune your boat's speed for best possible fuel economy and comfort.



Powertrim Assistant

Gives you the best possible drive trim – fully automatically – for perfect running attitude. Results in optimum performance and low fuel consumption.



Single-lever Mode

Operate twin, triple or quad engines with only one lever. Gives you easy control over speed even in rough seas.



Low-speed Mode

Reduces boat speed at idling by 50% from 5–6 knots to 2–3 knots. Integrated in the control. Perfect when you're driving in marinas and canals.

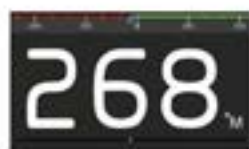

Autopilot

EVC-integrated, locks automatically to steering wheel course changes (shadow drive).



Tow Mode for water sport

Limits your boat's speed to your preset maximum rpm. Maintains the set speed and compensates for any changes in load, for maximum water sport fun.



Sportfish Mode

Makes it possible for you to rapidly turn your boat around its own axis – and follow the fish at high speed in reverse, using only the engine controls.



Joystick Docking

Makes docking easy, even fun. Forget complicated maneuvers in close quarters. Just move the joystick in any direction and your boat will follow. You can install up to six Joystick Docking stations on your boat.



Dynamic Positioning System

The Dynamic Positioning System is a perfect feature when you wish to automatically maintain your position and heading for a moment, i.e., when preparing for docking. With the repositioning feature, you can rotate the boat, move forward, backward and sideways, while remaining in DPS- mode – with just a simple tap of the joystick.



Joystick Driving

A whole new way to maneuver with precision at all speeds. You steer comfortably with the joystick. The integrated autopilot supports by automatically engaging after every course change.



Battery Management System

The system gives you a complete overview of battery status, helping you to manage your onboard electrical system.



Interceptor System

The robust and compact design of the Interceptor System (IS) ensures efficient and reliable trimming for Volvo Penta-powered yachts 35–100 feet. Fully integrated with EVC, it has become the perfect Auto-mode solution. Fully automatic trim adjustments will make your driving easier than ever. Available in sizes between 300–1,050 mm.



Glass Cockpit System

Gathers all driver information in one place – for enhanced overview and instant control of both navigation and engine. Learn more on page 18.

What is available for your drive system

Below is a selection of the wide range of features available for the current model year of Volvo Penta engines with EVC. We always recommend to order the features you want together with your new boat or when re-powering an existing one. However, many features can be installed by your Volvo Penta dealer at a later date.

Feature	Volvo Penta IPS	Aquamatic Sterndrive	Forward Drive	Inboard shaft
Trip computer	○	○	○	○
Cruise control	○	○	○	○
Powertrim Assistant	—	○	○	—
Single-lever Mode ¹⁾	○	○	—	○
Low-speed Mode	○	● ⁴⁾	—	○ ⁵⁾
Autopilot ²⁾	○	○	—	○
Tow Mode for water sport ²⁾	—	○	○	—
Sportfish Mode	△	—	—	—
Joystick Docking ³⁾	△	△	—	△
Dynamic Positioning System ³⁾	△	△ ⁴⁾	—	—
Joystick Driving ³⁾	△	△	—	△
Battery Management System	△	△	△	△
Electronic Steering	●	□/● ⁴⁾	—	□
Interceptor System ¹⁾	□	□	□	□
Glass Cockpit system 10"-24"	□	□	□	□

- 1) Twin, triple or quadruple installation
- 2) Single installation with side-mounted control
- 3) Requires electronic steering
- 4) DPI drives
- 5) D4-D13

Some features specified as options in the table may be included as standard in some markets.

Previous engine models

Many features are also available for previous engines with EVC. Talk to your dealer or go to www.volvopenta.com/compatibility-list for more information.

- Standard
- Factory installation recommended. Retrofit by dealer possible.
- △ Factory installation highly recommended. Retrofit by dealer possible, but can involve major installation work.
- Only factory installation. No retrofit.
- Not available

Note! Some features have to be factory installed and can only be ordered together with a new engine.

DRIVER INTERFACE

Volvo Penta's focus on easy and safe boating is reflected in our range of ergonomic controls, intuitive engine monitoring displays and easy-to-read gauges. In addition, our selection of stylish steering wheels will add that little extra to your helm station.

With the Glass Cockpit System at the helm, everything – navigation, drivelines and easy boating features – is brought together into one intuitive system. The result is a completely new level of control, comfort and driving pleasure.



EVC CONTROLS

State-of-the-art controls and joysticks deliver precise and effortless control. Fully integrated with the EVC System (Electronic Vessel Control) for maximum reliability and flexibility. Up to six helm stations can be installed, providing great opportunities to customize the boat to your specific requirements – for example – with a joystick docking station at the aft deck.



EVC top mount controls, twin engines



EVC top mount controls, single engine

EVC top mount – Single and twin engines

Top-mounted controls with a solid and ergonomic design. Electronic shift and throttle gives smooth and precise response to driver's commands. Conveniently located push-buttons for functions and optional features.

Available for Volvo Penta IPS, Aquamatic sterndrive and inboard installations. The top mount controls for twin engines also fits triple and quadruple engine installations.

Requirements:

EVC-D, E (Chrome)
EVC2 (Satin Grey)

Tailor your control

The table shows what features are available for your drive system.

Options	Volvo Penta IPS	Aquamatic Sterndrive	Diesel Inboard
Cruise control	●	●	●
Single lever mode ¹⁾	●	●	●
Low-speed mode	●	● ²⁾	● ³⁾
Powertrim Assistant	—	●	—
Trim Assist ^{1,4)}	●	●	●

1) Twin/multiple engines 2) DPI drives 3) D4-D13
4) With Interceptor system

Learn more about the optional features, see page 8.



EVC top mount HD – Single and twin engines

Developed for marine commercial use. The dark grey casing is extra durable and highly resistant to chemicals, such as diesel. All electronic components are housed externally to fully comply with classification rules. Available for IPS, Aquamatic sterndrive and inboard installations.

Requirements:

EVC-E4, EVC2

EVC top mount Classic – Single and twin engines

Top mounted controls featuring a classic design. Available in black finish or stainless steel. Electronic shift and throttle gives smooth and precise response to driver's commands. Available for Volvo Penta IPS, Aquamatic Sterndrive and inboard installations.



	Black controls		Stainless steel controls	
	Twin/Multiple	Single	Twin/Multiple	Single
EVC-B2 to E	21164029	21164027	21164033	21164031
EVC-A, B1, EDC	3819900	3819899	—	—



Joystick

Solid and ergonomic design provides perfect fingertip control. Integrated buttons for optional features such as Dynamic Positioning System and Joystick Driving.

Requirements:

EVC C-E (Chrome)
EVC2 (Satin grey)



Upgrade to the latest version of the joystick

The skipper's best friend has evolved over the years. If you have the first version, you can now upgrade to the latest, more ergonomic version of the Volvo Penta Joystick. Adapter cable is required.

Part no	Description
23066533	Joystick, chrome
21421926	Adapter cable (two cables required)





EVC side mount – Single Aquamatic sterndrive

The design offers a distinctive exterior with an ergonomic and solid feel. Electronic shift and throttle gives smooth and precise response to driver's commands. Conveniently located push-buttons for functions and optional features.

Requirements:

EVC-D, E (Chrome)
EVC2 (Satin Grey). Not for DPI drives.

EVC side mount – Single inboard

With its unique design, it combines an ergonomic and solid feel. Electronic shift and throttle gives smooth and precise response to driver's commands.

Requirements:

EVC-D, E (Chrome)
EVC2 (Satin Grey)

Tailor your control

The table shows what features are available.

Options	
Cruise control	•
Powertrim Assistant	•
Tow mode for water sport	•



Learn more about the optional features, see page 8.

The side mount control for Aquamatic sterndrive also features an integrated connection for safety lanyard. One cord is included with the control. For additional cords, see the table below.



Safety lanyard kit

The safety lanyard is an important safety device, particularly for fast open boats. It consists of two parts, a switch connected to the engine's electric system and a cord that is attached to the driver. Should the driver fall in the boat or fall overboard, the engine is automatically stopped.

Part no	Fits
3889798	TMD22-KAD300
3889799	Gasoline engines/D3 A-C
3817104	EVC-A to EVC-C
21469024	EVC-D, E, EVC2



Control panel

The control panel (optional) is an ideal complement to the side mount control for single inboard installations. It gives convenient access to smart features such as cruise control and low-speed mode.

Learn more about the optional features, see page 8.



Cord only

Part no	Fits
22027280	3889798-3889799
24003751	EVC side mount, Aquamatic
3858779	Xact sidemount, all generations

MECHANICAL CONTROLS

The Volvo Penta mechanical control heads are known for their quality, durability and excellent performance thanks to high-precision mechanics.

Xact Powerboat controls

The range of controls for mechanically operated engines has been developed with focus on ergonomics and safety. Easy to operate trim buttons and neutral safety switch are standard on all models. Pair that with a state of the art mechanism for smooth yet solid action, and you get a safe, robust and comfortable package.

Top mount

Great ergonomics, stylish looks and a state of the art mechanism guarantees a smooth yet solid experience.

Features and benefits:

- Neutral warm up - Release button for warming up the engine in neutral position.
- Neutral safety switch - Electrical neutral position switch, prevents engine being started in gear.
- Trim and tilt button - Tactile switch for simple operation of the drives trim and tilt.
- Master trim and tilt - Tactile switch to trim both drives (twin drives only).
- Friction adjustment - Adjustable friction brake for fine tuning.



Part no	Description
22928974	Single Top Mount with Trim switch and extension harness for trim connection (6 m)
22928976	Top Mount Twin installation with Trim switches and extension harness for trim connection (6 m)
22903907	Side Mount with Trim switch, safety lanyard and extension harness for trim connection (6 m)
22928971	Side Mount with Trim switch and safety lanyard

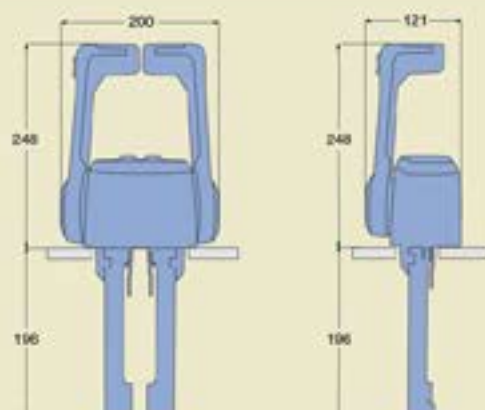

All controls have pre-mounted control mechanisms.

Side mount

With top class ergonomics, neutral interlock and safety lanyard it's the perfect choice for single engine installations. Designed for starboard side mount.

Features and benefits:

- Neutral interlock - Mechanical neutral position lock, prevents unintentional gear change.
- Neutral warm up - Release button for warming up the engine in neutral position.
- Neutral safety switch - Electrical neutral position switch, prevents engine being started in gear.
- Trim and tilt button - Tactile switch for simple operation of the drives trim and tilt.
- Safety cut-off switch - Connected to the included lanyard for emergency engine shut down.
- Friction adjustment - Adjustable friction brake for fine tuning.



Xact control cables available on page 17.

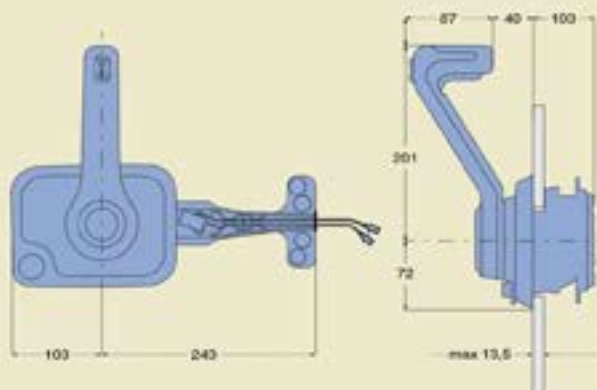

HOLE PATTERNS/CUTOUTS

Top mount twin

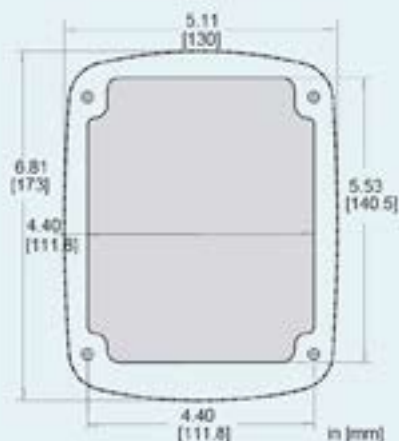

Top mount

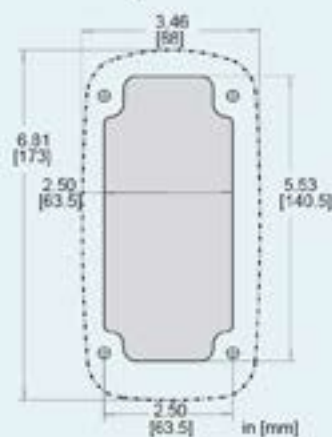

Side mount

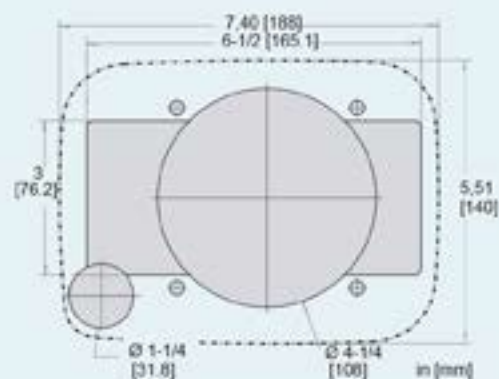

Sailboat control

The Volvo Penta mechanical sailboat control is designed with sailing and engine control in mind.

Features and benefits:

- Designed to minimize risk of rope entanglement
- Tough and robust, made for the harsh marine environment
- High quality stainless steel
- Splash protected installation
- Reliable and proven mechanism with adjustable friction brake
- Mechanism can be mounted horizontally or vertically
- Neutral safety switch available as option

Part No	Description
22688044	Lever & small cover (stainless steel)
851601	Mechanism
855352	Neutral safety switch
Select length	Control cable

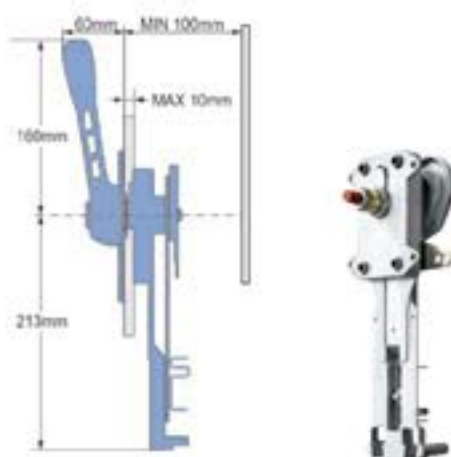

Upgrade your existing Volvo Penta sailboat control

If you have a previous model of Volvo Penta's sailboat control, you can easily upgrade to a new lever and a cover plate in stainless steel. If the existing control mechanism is in good condition, it does not need to be replaced.

Different upgrade options are available depending on the size of your current cover plate – consult the table.



Upgrading from large cover plate (107 x 166 mm)

Part No	Description
22576994	Lever (stainless steel)
22167713	Large cover plate* (stainless steel)
851601	Mechanism (for stainless steel cover plate)
853713	Large cover plate (black plastic)
1140095	Mechanism (for black plastic cover plate)
855352	Neutral safety switch

Upgrading from small cover plate (100 x 121 mm)

Part No	Description
22688044	Lever and small cover plate* (stainless steel)
851601	Mechanism
855352	Neutral safety switch

* If you keep the current control mechanism, minor modifications will be needed in order to fit the new stainless steel cover plate (detailed in the provided installation instructions).

Standard control cables

Volvo Penta's standard control cables are manufactured of corrosion-resistant material with an outer sheath of HD polyethylene. They are designed following Volvo Penta's extremely stringent requirements for efficient operation with minimum play. They are permanently lubricated to ensure minimum friction and long service life. Single engine installations require two cables, twin installations require four.

Part no	L, ft	L, m	Part no	L, ft	L, m
21633476	5	1.52	21633499	28	8.53
21633477	6	1.83	21633500	29	8.84
21633478	7	2.13	21633501	30	9.14
21633479	8	2.44	21633502	31	9.45
21633480	9	2.74	21633503	32	9.75
21633481	10	3.05	21633504	33	10.06
21633482	11	3.35	21633505	34	10.36
21633483	12	3.66	21633506	35	10.67
21633484	13	3.96	21633507	36	10.97
21633485	14	4.27	21633508	37	11.28
21633486	15	4.57	21633509	38	11.58
21633487	16	4.88	21633510	39	11.89
21633488	17	5.18	21633511	40	12.19
21633489	18	5.49	21633512	41	12.50
21633490	19	5.79	21633513	42	12.80
21633491	20	6.10	21633514	43	13.11
21633492	21	6.40	21633515	44	13.41
21633493	22	6.71	21633516	45	13.72
21633494	23	7.01	21633517	46	14.02
21633495	24	7.32	21633518	47	14.33
21633496	25	7.62	21633519	48	14.63
21633497	26	7.92	21633520	49	14.94
21633498	27	8.23	21633521	50	15.24

Xact control cables

Volvo Penta Xact Control Cables have been designed to provide the smoothest and easiest throttle/shift operation; while at the same time reducing lost motion. All fittings are stainless steel and plated brass. The all stainless steel armored strand core allows for greater flexibility and is capable of being put into tighter bends for those difficult cable routings.

Part no	L, ft	L, m	Part no	L, ft	L, m
21407218	3	0.91	21407240	27	8.23
21407219	4	1.22	21407241	28	8.53
3594991	4.7	1.43	21407242	29	8.84
3595377	5	1.52	21407243	30	9.14
40005275	6	1.83	21407244	31	9.45
21407220	7	2.13	21407245	32	9.75
21407221	8	2.44	21407246	33	10.06
21407222	9	2.74	21407247	34	10.36
21407223	10	3.05	21407248	35	10.67
21407225	12	3.66	21407249	36	10.97
21407226	13	3.96	21407250	37	11.28
21407227	14	4.27	21407251	38	11.58
21407228	15	4.57	21407252	39	11.89
21407229	16	4.88	21407253	40	12.19
21407230	17	5.18	21407254	41	12.50
21407231	18	5.49	21407255	42	12.80
21407232	19	5.79	21407256	43	13.11
21407233	20	6.10	21407257	44	13.41
21407234	21	6.40	21407258	45	13.72
21407235	22	6.71	21407259	46	14.02
21407236	23	7.01	21407260	47	14.33
21407237	24	7.32	21407261	48	14.63
21407238	25	7.62	21407262	49	14.94
21407239	26	7.92			



Xact

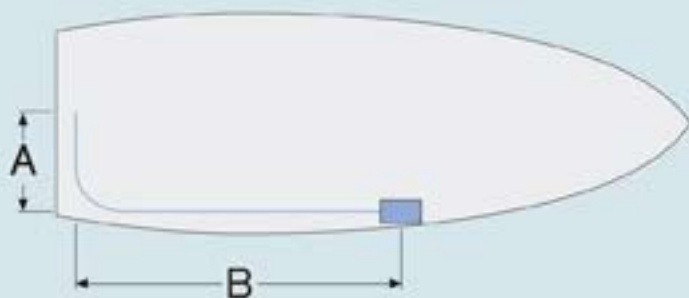

It is very important to select the exact cable length, fewer bends mean better operation and durability. Measure, in as straight a line as possible, the distance between the control mechanism and the engine/transmission connections. Calculate a radius of 200 mm for all bends. Adapt the cable as shown in the illustration $L = A + B + 200$ mm. If the measurement falls between two standard cable lengths, select the longer cable.

The cables must not be cut to size.



VOLVO PENTA GLASS COCKPIT SYSTEM

Allows you to monitor and control all driver information, including navigation, engine data, warnings, alarms and easy boating features, in one or more multi-function, touchscreen displays. The

screens come in several sizes, from 7" to 24". The Glass Cockpit system is offered as an option only when ordering a new engine, except for the 7-inch screen, which can be ordered at a later date.



Glass Cockpit Multi-Function Display (MFD) 7"

The 7-inch Multi-Function Display (MFD) is the perfect stand-alone solution for smaller boats. It allows you to monitor and control all driver information including; navigation, engine data, warnings and electronic features in one place. It consists of all-in-one solutions with built in GPS antenna and SD-card reader.

Features:

- Pinch-to-zoom and other multi-touch controls
- Fully integrated with Volvo Penta Electronic Vessel Control (EVC) monitoring features such as Dynamic Positioning System (DPS), Interceptors and Autopilot through the displays
- Heading and position refreshed 10 times per second
- Simplified SOS calling
- View and control your device from a smartphone or tablet
- Integrated NMEA 2000 and Wi-Fi connection.

Generation	Part no
EVC-E, EVC2	23316609

Mounting kit

Part no	Description
23316639	Bail and top mounting kit

ENGINE MONITORING DISPLAYS



2.5" display

The 2.5" display is an information center in a compact size. Features and data, see table.

Generation	Part no
EVC-D, E, EVC2	22499270



4" color display

The 4" full-color display is easy to read with custom screens. It shows all available information for one or two engines. Features and data, see table.

Generation	Part no
EVC2	23915762
EVC-D, E	23915762



7" color display

The 7" full-color display shows all available information for up to three engines in a new interface. Digital or analogue readers, your tailored view or standard view, etc. Active software functions, such as Low-speed Mode, are displayed. Operation is intuitive thanks to the easy to understand menus. Features and data, see table.

Generation	Part no
EVC-E	23811075
EVC-D	23811075
EVC-C3	23811075



4" display (b/w)

The 4" black and white display can show data from two engines at the same time, plus trip computer information.

Generation	Part no
EVC-C	22072254
EVC-B	22072190
EVC-A	3807827
EDC	22949191



Display engine data on your chartplotter

NMEA is a communication standard used to connect sensors, displays and other marine electronics to a network. With a NMEA interface, you can connect the engine to this network and enable engine data in a NMEA-compatible device, such as chartplotter or multi-function display.

Volvo Penta offers NMEA 0183 and NMEA 2000 interfaces to support the compatibility of your device. In addition, the Volvo Penta Easy Connect interface features both NMEA 2000 functionality and Bluetooth® connectivity, which offers even more opportunities. Learn more on page 6-7.

EVC Generation	System	Part no
EVC B-E, EVC2	NMEA 0183	3807587
EVC B-E, EVC2	NMEA 2000	22813366

Features and data

Engine monitoring displays	2.5"	4"	7"
Color screen		●	●
Day/night mode		●	●
Pop-up menus (shortcuts)		●	●
Video input			●
Neutral beep (on/off)	●	●	●
Engines displayed (max)	1	2	3
Engine rpm	●	●	●
Engine hours	●	●	●
Coolant temperature	●	●	●
Voltage	●	●	●
Oil pressure	●	●	●
Turbo pressure (diesel)	●	●	●
Alarms and warnings	●	●	●
Diagnostics in text	●	●	●
Diagnostics in text, extended info		●	●
Transmission, oil pressure *	●	●	●
Transmission, oil temperature *	●	●	●
Boat speed ¹⁾	●	●	●
Fuel level ²⁾	●	●	●
Fresh water level ²⁾	●	●	●
Depth with alarm ²⁾	●	●	●
Sea water temperature ²⁾	●	●	●
Rudder angle ²⁾	●	●	●
Powertrim angle (Aquamatic)	●	●	●
Active Corrosion Protection info ³⁾	●	●	●
Low-speed mode, slip rate ⁴⁾	●	●	●
With Trip computer software:	○	○	○
Instant fuel rate	●	●	●
Trip time	●	●	●
Trip fuel	●	●	●
Average fuel rate	●	●	●
Time to empty ²⁾	●	●	●
Instant fuel economy ³⁾	●	●	●
Trip distance ¹⁾	●	●	●
Average fuel economy ³⁾	●	●	●
Distance to empty ³⁾	●	●	●
With Dynamic Positioning System:			○
Bearing			●
Direction of movement			●
GPS signal strength			●

● Standard ○ Optional. *Depending on transmission. Requires sensors.

1) Requires extra sensor or NMEA interface.

2) Requires extra sensor.

3) Requires Active Corrosion Protection.

4) Requires low-speed mode.



EVC INSTRUMENTS

A complete range of instruments built to highest marine standards with an anti-fogging membrane and full backlighting. With EVC, precision and reliability are exceptional – and installation is easy thanks to serial connections.

1. Tachometer, 110 or 85 mm

Tachometer with engine hours and alarm symbols in the LCD-display.

Generation	Part no	Colour	RPM	Size
EVC C-E, EVC2	21511178	Black	0-4000	110 mm b)
EVC C-E, EVC2	21511176	White	0-4000	110 mm b)
EVC C-E, EVC2	21511183	Black	0-6000	110 mm
EVC C-E, EVC2	21511180	White	0-6000	110 mm
EVC C-E, EVC2	21628160	Black	0-4000	85 mm b)
EVC C-E, EVC2	21628159	White	0-4000	85 mm b)
EVC MC, EVC C	21628157	White	0-6000	85 mm

b) Also for D1/D2 with MDL

2. 4-in-1 gauge, 110 mm

Part no	Colour	Functions
3847876	Black	Coolant temp., voltage, oil pressure, fuel level a)
3885214	White	Coolant temp., voltage, oil pressure, fuel level a)
3847879	Black	Coolant temp., voltage, trim, fuel level
3885215	White	Coolant temp., voltage, trim, fuel level

a) Not D1/D2 and D3 A-C (-MY2008).

3. 4. Speedometer instrument, 85 mm

Part no	Colour	Speed
21234525	Black	0-40 knots, mph, km/h c)
21234528	White	0-40 knots, mph, km/h c)
21234529	Black	0-60 knots, mph, km/h c)
21234530	White	0-60 knots, mph, km/h c)
874916	Black	0-20 knots/23 mph d)
874917	Black	0-40 knots/45 mph d)

c) Figure 3. Unit selected in EVC system. Signal via GPS/NMEA or multi-sensor.

d) Figure 4. Signal via multi sensor.

Multi sensor: Transom mount 358/055. Through hull 358/054.

5. Fuel tank level instrument, 52 mm

Sensor 874840 is needed.

Part no	Colour
874914	Black
874926	White

6. Alarm instrument, 52 mm

7 alarms: Oil pressure, water in fuel filter, battery, coolant temperature, coolant level, oil level, fault/serious fault.

Part no	Colour
874915	Black
874927	White



Choose chrome or black front ring (must be ordered separately). See page 22.



7



8



11



12



9



10



13

7. Engine oil pressure instrument, 52 mm

Part no	Colour	Pressure	
874908	Black	0-7 bar	e)
874923	White	0-7 bar	e)
874919	Black	0-100 PSI	e)
874932	White	0-100 PSI	e)

e) Not D1/D2 and D3 A-C (-MY2009).

8. Engine coolant temperature instrument, 52 mm

Part no	Colour	Temperature
874904	Black	0-120° C
874921	White	0-120° C
874918	Black	40-250° F
874931	White	40-250° F

9. Water tank level instrument, 52 mm

Freshwater level sensor 3809098 is needed.

Part no	Colour
3809992	Black
3809993	White

10. Rudder position instrument, 52 mm

For conventional steering system^{f)} also order sensor kit 3809099, DPH/DPR also require mounting kit 3594073.

Part no	Colour
3812914	Black
3812917	White

f) Sensor and mounting kits are not needed for IPS or Aquamatic/rboard with electronic steering.

11. Drive trim position instrument, 52 mm

Part no	Colour
3812881	Black
3812911	White

12. Turbo pressure instrument, 52 mm

Part no	Colour	Interval
874910	Black	0-3 bar
874924	White	0-3 bar

13. Battery voltage instrument, 52 mm

Part no	Colour	Voltage
881649	Black	12 V
881658	White	12 V
874913	Black	24 V
874925	White	24 V

Oil temperature instrument, 52 mm

Part no	Colour	Temperature
874905	Black	0-150° C
874922	White	0-150° C
881857	Black	40-300° F

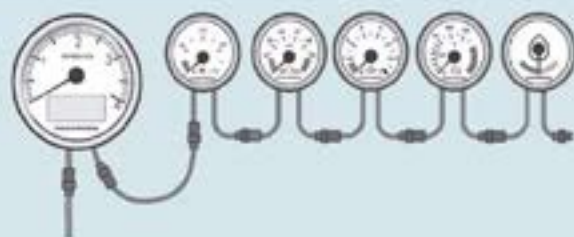

Adding instruments is easy thanks to plug-and-play serial connections.



Easy Connect is an ideal complement to the mounted instruments at the helm. Learn more at page 6.



Mounting kit with front ring

A. Panel thickness up to 12 mm/15 mm

Part no	Instrument diameter	Panel thickness	Description
874709	52 mm	0-12 mm	Black ring
874708	85 mm	0-12 mm	Black ring
3847888	110 mm	0-15 mm	Black ring
874733	52 mm	0-12 mm	Chrome ring
874732	85 mm	0-12 mm	Chrome ring
3885216	110 mm	0-15 mm	Chrome ring

B. Panel thickness 12-25 mm

Part no	Instrument diameter	Panel thickness	Description
881611	52 mm	12-25 mm	Black ring
881612	85 mm	12-25 mm	Black ring
881613	52 mm	12-25 mm	Chrome ring
881614	85 mm	12-25 mm	Chrome ring



X-ring for flush mounting

Part no	Instrument diameter	Description
874843	52 mm	Flush mounting
874844	85 mm	Flush mounting
3886791	110 mm	Flush mounting

Auxiliary Dimmer Unit (ADU)

The ADU makes it possible to dim all your EVC-instruments through the EVC main panel.

Part no
3848966



INSTRUMENT RANGE FOR NON-EVC GASOLINE ENGINES

Volvo Pentas instruments for non-EVC gasoline engines are based on the well proven design concept used by the EVC instruments, but modified to be able to communicate with all gasoline applications produced 2008 or later. With the tachometer gateway (easy link), additional EVC gauges will be available to form a complete dashboard range.

Instrumentation

The tachometer is available both in black or white, and has monochrome display for engine hours and instant fuel rate.

Included in the tachometer is an easy-link gateway which makes it possible to connect instruments for drive trim, oil pressure, coolant temperature and charging voltage.

The speedometer features a built-in GPS for accurate speed, and has a display for viewing COG and heading.

Part no	Description
23040335	Tachometer 85 mm, 6000 RPM, white dial
23040364	Tachometer 85 mm, 6000 RPM, black dial
23045964	Speedometer 85 mm, 60 knots, white dial
23045963	Speedometer 85 mm, 60 knots, black dial
23190000	Cable (7 m) between engine and tachometer. (required)
874759	1 m – extension cable, tachometer to additional instruments
3807043	3 m – extension cable, tachometer to additional instruments



Note! Front ring and mounting items are not included with the instruments. See page 22.

Applicable instrument

In addition to the tachometer and speedometer, the instruments below can also be connected. Please see page 20-21 for more information regarding the instruments. All instruments are available with white or black dial.



Engine oil pressure



Engine coolant temperature



Drive trim position



Fuel tank level



Battery voltage



INSTRUMENTS FOR NON-EVC ENGINES

Volvo Penta's range of instruments for non-EVC diesel and gasoline engines offer a modern appearance and a high level of readability. The gauges are available in 85 mm and 52 mm and designed to fit in previous instrument panels for Volvo Penta non-EVC engines. Complete instrument panel kits are also available.



Instrument panel kit - Main station

Main station kit available in two versions, 12V or 24V. Add a 4000 rpm or 6000 rpm tachometer for a complete installation.

Includes:

- Instrument panel with alarm display
- Coolant temperature gauge, engine, 40°C-120°C
- Oil pressure gauge, engine, 0-10 bar
- Voltmeter, 8-16V, (in 12V kit)
- Voltmeter, 16-32V, (in 24V kit)
- Starter switch, key lock

Dimensions: 250 x 190 mm

Part no	Description
23577077	Instrument panel kit, 12V
23577080	Instrument panel kit, 24V

Cover plate

To cover the tachometer opening in the instrument panel if a tachometer is not installed.

Part no
858648



Instrument panel - Flybridge

Same panel as the main station panel but in a mirrored design. Excluding instruments, lamps and switches. Dimension 250 x 190 mm.

Part no	Description
860184	Instrument panel



Instrument panel kit - Oil and turbo pressure

Includes:

- Instrument panel
- Oil pressure gauge, gear box 30 bar
- Turbo pressure gauge, 3 bar

Dimensions: 90 x 190 mm

Part no	Description
23577092	Instrument panel kit, 12/24V



Instrument panel kit - Secondary station

Flybridge or secondary station panel with alarm display and starter switch. Add a 4000 rpm or 6000 rpm tachometer for a complete installation.

Dimensions: 180 x 140 mm

Part no	Description
23577084	Instrument panel kit, 12/24V



Alarm panel display

Used when alarm functions are moved from the instrument panel and separately installed. The panel contains symbols for coolant temperature, oil pressure, battery charging and pre-heater.

Note! The display panel is merely an empty housing, the required connections, lamps, etc., must be taken from the instrument panel.

Dimensions: 113 x 50 mm

Part no	Description
858876	Alarm panel display



1. Tachometer kit, 85 mm

Tachometer with engine hours in the LCD-display. Available in 4000 rpm and 6000 rpm. Adapter cable / wiring harness, mounting kit and front ring are included.

Tachometer compatibility, see information on the next page.

Part no	Description
23715874	Tachometer kit, 4000 rpm, 12/24V
23715875	Tachometer kit, 6000 rpm, 12/24V

2. Engine coolant temperature gauge, 52 mm

Scale 40°-120°C. Adapter cable / wiring harness, mounting kit and front ring is included.

Part no	Description
23715849	Engine coolant temperature gauge, 12/24V. Input signal: 287 – 22,7 Ω

3. 4. Voltmeter, 52 mm

Adapter cable / wiring harness, mounting kit and front ring is included.

Part no	Description
23715881	Voltmeter, 8-16V, 12V
23715883	Voltmeter, 18-32V, 24V

5. Oil pressure gauge, gear box, 52 mm

Scale 30 bar. Adapter cable / wiring harness, mounting kit and front ring is included.

Part no	Description
23715885	Oil pressure gauge, gear box, 12/24V Input signal: 10 – 211 Ω

6. Oil pressure gauge, engine, 52 mm

Scale 10 bar. Adapter cable / wiring harness, mounting kit and front ring is included.

Part no	Description
23715880	Oil pressure gauge, engine, 12/24V Input signal: 10 – 184 Ω

7. Turbo pressure gauge, 52 mm

Scale 3 bar. Adapter cable / wiring harness, mounting kit and front ring is included.

Part no	Description
23715887	Turbo pressure gauge, 12/24V Input signal: 10 – 181 Ω

Flush mounting kits

The kits include o-ring, fixing brackets and nuts for flush mounting of instruments.

Part no	Description
23901708	Flush mounting kit*, for instrument 52 mm
23901709	Flush mounting kit*, for instrument 85 mm

* Kit will be available in quarter two 2021.





Tachometer, 85 mm.
See previous page for specifications.

Tachometer compatibility

The tachometer can read various types of input signals. Installation instructions with code table for setting correct RPM (depending on engine family) is supplied with the tachometer kit.

The tachometer is compatible with diesel and gasoline (non EVC) engines and can read the following input signals:

Ignition pulse:

4, 6 and 8-cylinder gasoline engines

Alternator W pulse:

2001-2003T
MD2010-MD2040
MD/TMD/TAMD22
D30-40
D31/32/41/42/43

Inductive pulse:

MD5, MD6, MD7, MD11, MD17
D1-13/20/30 (without MDI)
D2-40/55/75 (without MDI)
MD21/32, AOD21/32
KAD/KAMD44/300



Main station panel with the tachometer (option).



Fuel gauge, kit

The fuel gauge shows the quantity of fuel in the fuel tank. The sensor, which is installed in the fuel tank, is equipped with a float that follows the level of fuel in the tank.

Includes: instrument 863940, sensor 873772, cables and front ring.

Part no

873808



Front ring for instruments

Part no	Instrument diameter	Hole diameter
858643	52	60
873517	72	90



Toggle switch

Part no

814322



Digital Power Trim instrument kit

Equipped with display showing the trim angle of the drive. Control unit 3855650 is suitable to operate the Power Trim.

Note! 3855650 must be ordered separately.

Part no	Drive
872498	DP-E/DP-G
3819708	SX/DP-S



Analog Power Trim instrument

For SX/DP-S drive. Shows the drive trim angle. Control unit 3855650 is suitable to operate the Power Trim.

Part no
3851787



Power Trim control unit

Part no
3855650



Rudder indicator kit

The indicator shows the steering angle of the rudder and is an invaluable aid when manoeuvring and mooring in crowded harbours.

Includes: Instrument, sensor, cables and front ring.

Part no	Description
1140465	Rudder indicator kit, 12V

Rudder indicator kit for Aquamatic sterndrives

The indicator shows the drive steering angle and is an invaluable aid when manoeuvring and mooring in crowded harbours. Complete kit for connection of sensor to the steering arm of the drive. Fits drives: 290, SP A-C, DP A-E, DP-S, DPG.

Includes: Instrument, sensor, cables, front ring and connection parts.

Part no	Description
1140463	Rudder indicator kit for drives, 12V

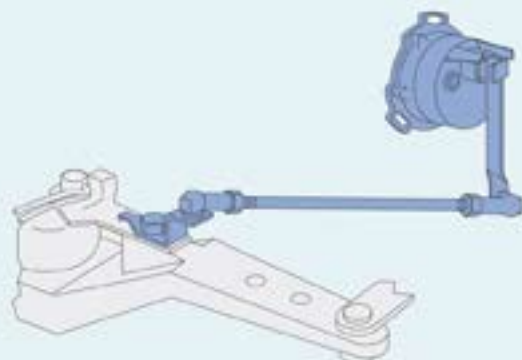

STEERING WHEELS AND STEERING SYSTEM

Volvo Penta offers reliable mechanical and hydraulic systems. Both systems have zero feed back function so the steering is not affected by forces such as waves etc. All Volvo Penta steering wheels are specially adapted to marine conditions, which means that they are anti-magnetic and made of corrosion resistant materials.



Steering wheels

- Designed to match Volvo Penta controls and displays
- Non-magnetic stainless steel
- High-quality materials
- Fits most types of steering system
- Steering wheel hub included
- Conforms with the EN 28848 standard of the Recreational Craft Directive (2013/53/EU) and with the ABYC P22 Safety standards for Steering Wheels.



Model	Classic Mahogany	Leather / Chrome	Stainless	Leather / Satin grey
Part no	21729995	21649809	21673214	23799729
Grip	Mahogany	Leather	316 Stainless steel	Leather
Spokes	316 Stainless steel	304 Stainless steel	316 Stainless steel	304 Stainless steel
Recommended use	Indoor/Cabin	Indoor/Cabin	Outdoor	Indoor / Cabin
Diameter	350 mm	350 mm	370 mm	350 mm
Mounting	Std 3/4" tapered shaft	Std 3/4" tapered shaft	Std 3/4" tapered shaft	Std 3/4" tapered shaft

Hydraulic Steering

The strength required to steer a boat equipped with a hydraulic steering system is inversely proportional to the number of turns of the wheel lock-to-lock. The wheel turns are determined by the ratio between the cylinder volume, the pump displacement and the free movement of the steering device, e.g. the rudder. A large cylinder volume and small pump displacement results in a greater number of wheel turns and a small cylinder volume and a large pump displacement results in less number of wheel turns.

Fewer wheel turns means quicker steering response but more effort needed and more wheel turns means slower steering response but less effort. The Hydraulic Steering Helm pumps are available in three different displacement sizes, i.e. 28 cc, 33 cc and 39 cc. Each of them are available for three different ways of mounting, i.e. front mount, rear mount and tilt mount. Three steering cylinders are available, all for rudder installations, and comprising volume 116 cc, 168 cc and 215 cc respectively.

Adjustable steering wheel

The tilt mechanism allows for five locking positions in the range of 48 degrees (+/- 24 degrees) tilt angle of the Steering Wheel. With the tilt steering mechanism, the boat driver can choose the best personal steering wheel angle.



Hydraulic Steering

Part no	Displ./rev	Max. wheel dia.	No. of pistons	Pump	Relief valve setting	Weight, kg
22275070	28 cc	711 mm	5	Front mount helm pump	70 bar	5 kg
22275071	33 cc	711 mm	7	Front mount helm pump	70 bar	5 kg
22275072	39 cc	711 mm	7	Front mount helm pump	70 bar	5 kg
22275073	28 cc	711 mm	5	Rear mount helm pump	70 bar	5 kg
22275074	33 cc	711 mm	7	Rear mount helm pump	70 bar	5 kg
22275075	39 cc	711 mm	7	Rear mount helm pump	70 bar	5 kg
22275076	28 cc	508 mm	5	Tilt mount helm pump	70 bar	5 kg
22275077	33 cc	508 mm	7	Tilt mount helm pump	70 bar	5 kg
22275078	39 cc	508 mm	7	Tilt mount helm pump	70 bar	5 kg
22299003				Tilt mechanism		

a) Requires the tilt mechanism, which has to be ordered separately.

Steering cylinders for hydraulic steering

Part no	3/8" (9,5 mm) fittings	Output force	Stroke	Torque	Volume, cm ³
3809981	For high pressure flexible hose	455 kg	178 mm	53 kgm	116
3809982	For high pressure flexible hose	682 kg	178 mm	87 kgm	168
3809983	For high pressure flexible hose	682 kg	228 mm	111 kgm	215

Connecting kit, etc.

Part no	Description
1140584	Hydraulic high pressure flexible nylon hose 3/8"
192618	Air bleed hose
22618337	Hydraulic oil, 1 litre

Tie bar for twin engine installations

Part no	CC between engines	Fits drive
3841706	660-1040 mm	SX/DP-S
3841707	840-1220 mm	SX/DP-S
3594639	1000-1240 mm	DPH/DPR



Mechanical Steering

The mechanical steering helms are available in four models, all using a Planetary Gear Design with three satellite gears that rotate on their axis and at the same time rotate around the central helm axis. This design provides an optimum reduction ratio with a minimum of physical effort, increased efficiency and less torque feedback compared to cheaper single pinion gear helms.

No feedback helms

A special patented device allows the helm shaft to lock until turned by the driver, maintaining the boat direction and neutralizing the feedback loads on the steering cable. The mechanism is engaged when the driver applies pressure on the wheel to change direction of the boat.



Image	Part no	Description	
2	21580928	Rear mount planetary helm gear	a)
2	21580930	Rear mount planetary helm gear, No-Feedback	a)
1	21580932	Planetary helm gear for tilt mount	b)
1	3818027	Planetary helm gear, No-Feedback for tilt mount	b)
4	21580825	Bezel kit - for 90° mounting, black	
	3818096	Bezel kit - for 70° mounting, black	
3	3883508	Bezel kit - for 70° mounting, white	
1	22299003	Tilt mechanism	

a) Requires a bezel kit for the installation. Has to be ordered separately.
b) Requires the tilt mechanism, which has to be ordered separately.

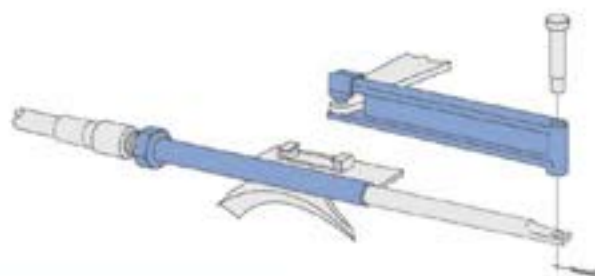

Steering cable attachment

This steering cable attachment is used to attach the steering cable on DP-E drives without power steering.

Part no
872388

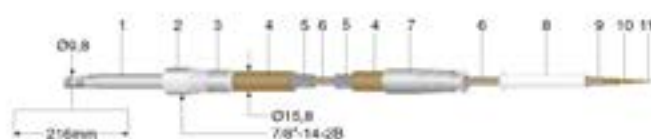

Steering cable

Volvo Penta steering cables are high quality products designed to provide optimum efficient performance, i.e., a minimum of physical effort with a minimum of play.

1. Telescopic sleeve
2. Connection nut
3. End sleeve
4. Protective outer sheathing in brown HD polyethylene
5. Hardened steel wire armature
6. Inner cable
7. End sleeve
8. Protective sleeve in white HD polyethylene
9. Spring steel covering
10. 36 strand steel wire – laid to left and right
11. Core wire

Part no	Cable length, m
3848176	2.00
3848177	2.25
3848178	2.50
3848179	2.75
3848180	3.00
3848181	3.25
3848182	3.50
3848183	3.75
3848184	4.00
3848185	4.25
3848252	4.50
3848253	4.75
3848254	5.00
3848255	5.25
3848347	5.50

Part no	Cable length, m
3848348	5.75
3848349	6.00
3848350	6.25
3848351	6.50
3848352	6.75
3848353	7.00
3848354	7.25
3848355	7.50
3848356	7.75
3848357	8.00
3848358	8.25
3848359	8.50
3848360	8.75
3848517	9.00

BOAT TRIM SYSTEM



The Boat Trim System (BTS) with its patented interceptor technology gives you perfect control over pitch and heel with rapid response, quicker onto plane, lower fuel consumption and a more comfortable ride. Even better, add the Automatic Boat Trim option which takes over the task of keeping the boat correctly trimmed - automatically!

This trim system is a perfect match for almost all planing boats in the range of 17 to 40+ feet. Outboard, sterndrive or inboard does not matter, it's compact design make for an easy installation. The kits come with a comprehensive installation guide which mean upgrading from conventional trim tabs is a small job.

You get

- Improved fuel efficiency.
- Greater lift and less drag compared with conventional trim tabs.
- Quickly onto the plane.
- Intuitive, user-friendly control panel.
- Automatic Boat Trim functionality (option)

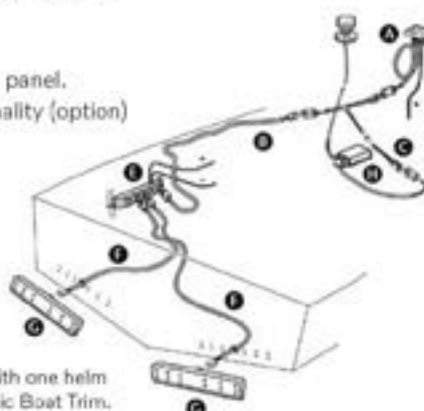

Single installation with one helm station and Automatic Boat Trim.

BTS 300 mm kit, Part no 21914554

2 Interceptor units, 300	2 x 22656800
1 Control panel	1 x 21809318
1 Control unit	1 x 21546221
2 Cables, 2,5 m	2 x 3817171
1 Cable, 5 m	1 x 23561737

BTS 450 mm kit, Part no 21914555

2 Interceptor units, 450	2 x 22656801
1 Control panel	1 x 21809318
1 Control unit	1 x 21546221
2 Cables, 4 m	2 x 3817172
1 Cable, 9 m	1 x 23561739

Automatic Boat Trim kit, Part No. 21561103 ***

1 GPS receiver	1 x 3847459
1 Attitude control unit	

Ordering and component guide

Description	Part no	1 helm station					2 helm stations*				
		2x300	2x450	2x300+ 2x450	4x300	4x450	2x300	2x450	2x300+ 2x450	4x300	4x450
Mandatory components											
A Control panel	21809318	1	1	1	1	1	2	2	2	2	2
6-pole cable (select length)		1	1	1	1	1	1	1	1	1	1
5 m	23561737										
B 7 m	23561738										
9 m	23561739										
11 m	23561740										
13 m	23561741										
C 6-pole Y-cable	3588972						1	1	1	1	1
6-pole extension cable (select length)							1	1	1	1	1
1,5 m	3889410										
3 m	3842733										
D 5 m	3842734										
7 m	3842735										
9 m	3842736										
11 m	3842737										
E Control unit	21546221	1	1	1	1	1	1	1	1	1	1
4-pole cable (select length)		2	2	4	4	4	2	2	4	4	4
F 2,5 m	3817171										
4,0 m	3817172										
G Interceptor unit 300 mm	22656800	2		2	4		2		2	4	
Interceptor unit 450 mm	22656801		2	2		4		2	2		4
Optional component											
H Automatic Boat Trim ***	21561103	1	1	1	1	1	1	1	1	1	1
Resettable breaker BA **	966689	2	2	2	2	2	2	2	2	2	2

* Note! For each extra helm station (max 4 helm stations possible), add one control panel (A), one 6-pole Y-cable (C) and one 6-pole extension cable (D).

** Note! If the boat does not have a separate fuse box accessible, Volvo Penta resettable BA breaker may be used. 966689 is not ignition proof and must therefore not be used in gasoline engine rooms.

*** Note! For the installation one 6-pole Y-cable (C) is always needed. Depending on installation type, there might be a need for a 6-pole extension cable (D). The 6-pole cable on the Attitude control unit (H) is approx. 25 cm.

ENGINE ACCESSORIES

Every accessory is a part in a system. They are all designed and developed to work together. All accessories fulfill our tough demands of durability and reliability. They are tailor made designed for easy mounting to engine and drive, eliminating complicated adaptations and tested as carefully as the engine.



Fuel filter/water separator, diesel engines

Fuel filter/water separator for small diesel engines. The filter is intended for installation between the fuel tank and the engine. The filter is supplied without connection parts for the fuel lines (see "Fuel line fittings").

Part no

877766

Filter element for 877767 and 877766

Part no

358107B



Fuel filter/water separator, diesel engines

The filter is intended for installation between the fuel tank and engine. Three progressive stages – separation, coagulation and filtration ensure that fuel arrives at the engine free from contamination. The filter is prepared for connection of a water alarm.

The filter is supplied without connectors or union nuts for fuel line connection (see "Fuel line fittings").

Weight: 2 kg

Flow, max.: 227 l/hour

Degree of separation: 10 micron

Initial pressure drop at max. fuel flow, 10 micron filter element: 4.1 kPa

Recommended filter: Replaceable filter element 861014, 3581760.

Part no	Description
877763*	white metal bowl
22677639*	see through bowl

* Complies with applicable parts of RCD 2013/53/EU Harmonized standard EN ISO 10088. Complies with Classification Society requirements for fuel systems for propulsion engines.

Filter element for 877762, 877763, 877764 and 22677639

Part no	Micron
861014	10
3581760	30
1147147	2

FUEL SUPPLY

A reliable supply of clean fuel to the engine. Nothing is more important for reliability and safety at sea.

Water in Fuel Alarm

To get an early warning for water in the fuel tank the best position for a water sensor is in the Fuel Filter/Water separator between the tank and the engine. The sensor will detect water in the bowl of the water separator and give the early warning wanted.



Water in Fuel Alarm (D3, D4 and D6)

For D3-D6 engines a new sensor is developed that e.g. fits fuel filter / water separator 877763, 877768 & 877764. The sensor is connected to the EVC system and will give you the alarm in your EVC instrumentation. It also works in parallel with an existing engine-mounted 'water in fuel' alarm.

The kit fits D3/D4/D6 engines produced 2011 and later (which have paired engine cable harness). For 12 V or 24 V systems.

Part no

21641493



Water in Fuel Alarm (Stand-alone)

When detecting water the system will warn with both a warning lamp and audio signal (buzzer).

Suitable for use in conjunction with fuel filters/water separators 877762, 877769, 877768, 877770, 877763, 877771, 889280. For 12 V or 24 V systems.

Part no

1140724



Fuel filter/water separator, diesel engines

For heavier diesel engines used in demanding environments with inconsistent fuel quality. Three progressive stages – separation, coagulation and filtration ensure that fuel arrives at the engine free from contamination.

All metal filter. Filter is adapted for connecting to water alarm. Complies with US Coast Guard standards for 2.5 minutes fire resistance in open flames. The filter is supplied with a 10 micron filter element, but without connectors or union nuts for fuel line connection (see "Fuel line fittings").

Weight: 3 kg

Flow, max.: 341 l/hour

Degree of separation: 10 micron

Initial pressure drop at max. fuel flow, 10 micron filter element: 2.3 kPa

Recommended filter: Replaceable filter element 3838852 and 889419

Part no	Description
877768*	white metal bowls
22677640*	see through bowls

* Complies with applicable parts of RCD 2013/53/EU Harmonized standard EN ISO 10088. Complies with Classification Society requirements for fuel systems for propulsion engines.

Filter element for 877769, 877768 and 22677640

Part no	Micron
3838852	10
889419	30
889421	2



Filter element for 877771, 889280 and 889281

Part no	Micron
3838854	10
889422	30
889425	2

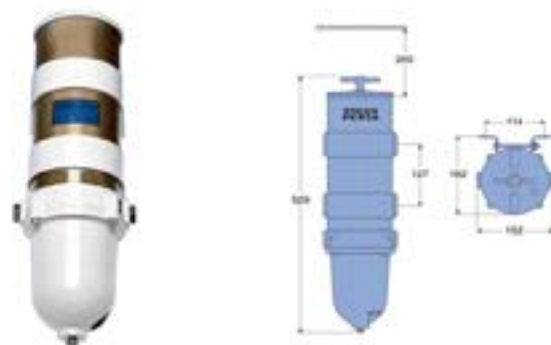

Fuel filter/water separator, diesel engines

For heavier diesel engines used in demanding environments with inconsistent fuel quality. The filter is intended for installation between the fuel tank and engine. Three-stage filtration – centrifugal separation, coagulation and filtration. Water and impurities are collected in the bowl beneath, from which they can be drained off by means of a drain valve.

All metal construction. Complies with US Coast Guard requirements for fire resistance on exposure to naked flame for 2.5 minutes. Filter is adapted for connecting to water alarm. Filter is supplied with a 10 micron filter element, but without connectors for fuel line connection (see "Fuel line fittings").

Weight: 5 kg

Flow, max: 681 l/hour

Degree of separation: 10 micron

Initial pressure drop at max. fuel flow, 10 micron filter element: 3.4 kPa

Recommended filter: Replaceable filter element, 3838854 and 889422

Part no
877771*

* Complies with applicable parts of RCD 2013/53/EU Harmonized standard EN ISO 10088. Complies with Classification Society requirements for fuel systems for propulsion engines.

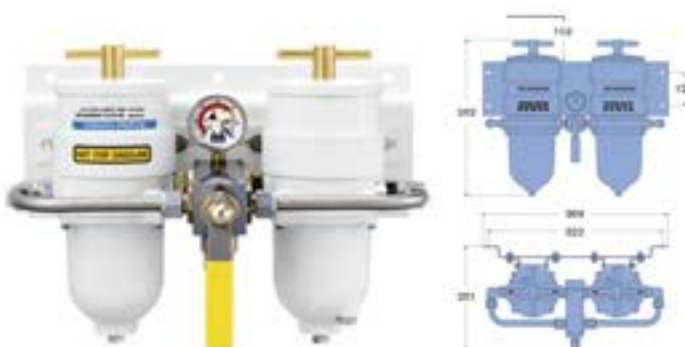

Double fuel filter/water separator, diesel engines

Weight: 7,7 kg

Flow, max.: 454 l/hour

Degree of separation: 10 micron

Initial pressure drop at max. fuel flow, 10 micron filter element: 4.83 kPa

Recommended filter: Replaceable filter element 861014

Fuel port connection 3/4"-16 UNF

Part no
877764*

* Complies with applicable parts of RCD 2013/53/EU Harmonized standard EN ISO 10088. Complies with Classification Society requirements for fuel systems for propulsion engines.



Double fuel filter/water separator, diesel engines

For heavier diesel engines used in demanding environments with inconsistent fuel quality.

All metal double filter with pressure gauge showing the pressure drop. Connections can be made between left hand, right hand or both filters, thus making it possible to change filter elements with the engine running. The filter thereby complies with Classification Association standards for propulsion engine fuel systems as well as the US Coast Guard standards for 2.5 minutes fire resistance in open flames.

Filter is adapted for connecting to water alarm. The filter is supplied with a 10 micron filter element, but without connectors or union nuts for fuel line connection (see "Fuel line fittings").

Weight: 10.4 kg

Flow, max.: 682 l/hour

Degree of separation: 10 micron

Initial pressure drop at max. fuel flow, 10 micron filter element: 12.4 kPa

Recommended filter: Replaceable filter element 3838852 and 889419

Part no
877770*

* Complies with applicable parts of RCD 2013/53/EU Harmonized standard EN ISO 10088. Complies with Classification Society requirements for fuel systems for propulsion engines.



Fuel filter/water separator - twin diesel engines

For heavier diesel engines used in demanding environments with inconsistent fuel quality. Twin filter with gauge that indicates pressure drop. Transparent bowls fitted with heat shields. Can be connected to right, left or both filters to allow filter replacement while running.

Complies with classification body requirements for fuel systems for propulsion engines. Also complies with US Coast Guard requirements for fire resistance on exposure to naked flame for 2.5 minutes. The filter is supplied with a 10 micron filter element, but without connectors for fuel line connection (see "Fuel line fittings").

Weight: 11.3 kg (Metal bowls: 13.6 kg)

Flow, max: 1363 l/hour

Degree of separation: 10 micron

Initial pressure drop at max. fuel flow,

10 micron filter element: 24.1 kPa (Metal bowls: 25.5 kPa)

Recommended filter: Replaceable filter element,

3838854 and 889422

Part no	Description
889280*	see through bowls
889281**	white metal bowls

* Complies with applicable parts of RCD 2013/53/EU Harmonized standard EN ISO 10088

** Complies with applicable parts of RCD 2013/53/EU Harmonized standard EN ISO 10088. Complies with Classification Society requirements for fuel systems for propulsion engines.

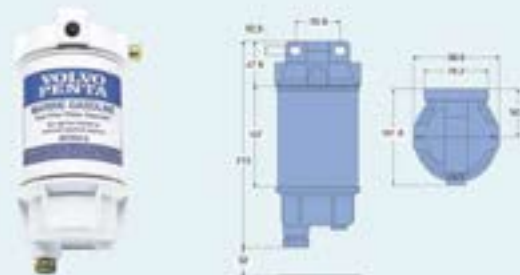

Extra fuel filter, gasoline engines

The filter element is of the disposable spin-on type. The filter is supplied with a 10 micron filter element, but without connectors or union nuts for fuel line connection (see "Fuel line fittings").

Weight: 0.9 kg

Flow, max: 227 l/hour

Degree of separation: 10 micron

Recommended filter: Replaceable filter element, 857633

The product fulfils the requirements of Recreational Craft Directive 94/25/EC.

Part no
877765*

* Complies with applicable parts of RCD 2013/53/EU Harmonized standard EN ISO 10088.



Filter element for 877765

Spin-on disposable filter, 10 micron.

Part no
857633



Fuel Hose

High quality fuel hose for commonly available fuels such as diesel, biodiesel, gasoline and ethanol based fuels. Inner tube of FPM (Fluorinated Propylene Monomer), middle tube of ECO and a CSM cover. This gives it the capability to handle e.g. biodiesel, very low permeability and the ability to withstand high temperatures (-40°C to +120°C).

Fire resistant according to ISO7840 and ISO15540/15541. Type approved by D.N.V. and M.E.D certified (Wheelmarked).

Supplied per metre.

Part no	Int. Ø, mm	Ext. Ø, mm
3830315	9,5	16,5



Fuel hose

Fuel hose, fire resistant in accordance with ISO7840-A1 and J1527 USCG type 2. Internal diameter 3/8". Supplied per metre. Recommended stainless steel hose clips, part no. 961664.

The product fulfils the requirements of Recreational Craft Directive 94/25/EC.

Part no	Int. Ø
861057	Fuel hose 3/8" (9,5 mm)



Fuel level sensor

The fuel level sensor provides an all-in-one solution for the fuel tank. Level sensor, fuel in- and outlet ports for main engine, in- and outlet ports for diesel heater, de-aeration and fuel pickup / return pipe all integrated in one package. The bayonet fitting means it is easy to install together with our service hatch. M18 connections for fuel outlet port and M16 for fuel return port.

Part no	Length*
22682855	472 mm
22682856	527 mm
22682858	627 mm
22682859	676 mm

* Length from top of inside tank to bottom of level sensor



Service hatch

A service hatch designed with a laser cut bayonet hole for easy installation of the level sensor. Made of electro polished stainless steel with a 38 mm fuel fill connection. Delivered as a kit including screws, gaskets, flange and installation instruction. Volvo sealant 1161099 needs to be ordered separately.

Part no
22548277

Part no: 877763

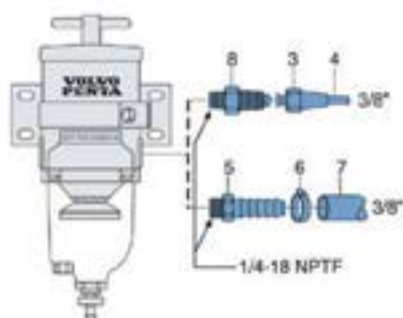

Part no: 877768, 877769

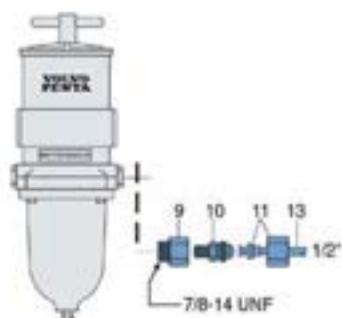

Part no: 877770, 889280, 889281

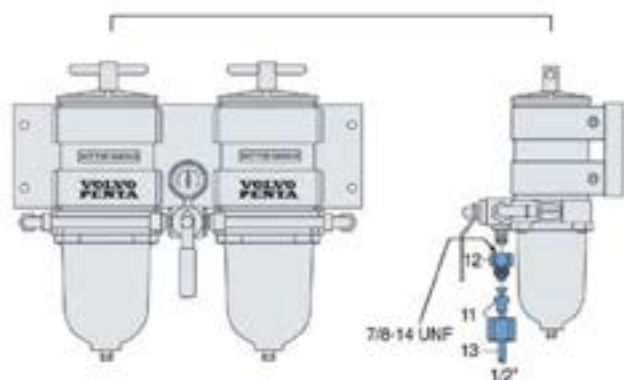

Part no: 877771

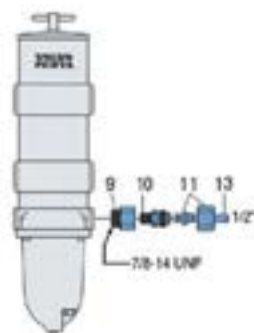

Part no: 877766

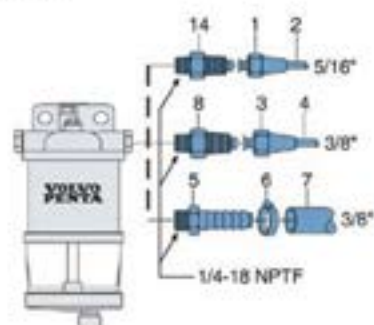

Part no: 877765

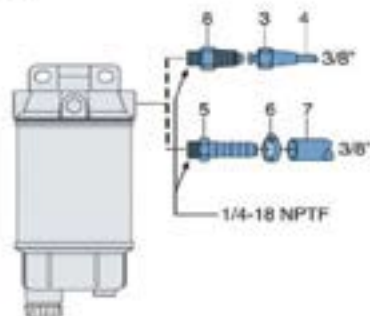

Fuel line fittings

Part no	No	Description
954322	1	Union nut 5/16"
954305	2	Copper pipe 5/16"
954323	3	Union nut 3/8"
1140062	4	Copper pipe 3/8", 25 m
3825000	5	Hose connector
961664	6	Hose clamp
861057	7	Fuel hose 3/8"
954337	8	Connector 3/8"
3825034	9	Adapter fitting
3825512	10	Connector 1/2"
3825513	11	Union nut 1/2"
3825511	12	Adapter fitting
-	13	Copper pipe 1/2", not stocked by Volvo Penta
190962	14	Connector 5/16"

EXHAUST SYSTEM

Complete systems with silencers, hoses, elbows and everything else needed. Perfectly in tune with the respective engine series.



Rubber exhaust hoses

An flexible exhaust hose for marine wet exhaust systems that conforms with ISO13363 type 2 (+580°C) and SAE J 2006 type R2. It's minimized bend radius means easy and quick installation. Reinforced by synthetic textile layers and embedded steel wire helix it has plain and smooth inner surface for minimum exhaust back pressure. Smooth outer surface. Sold per meter.

Part no	Min. bend radius mm	Rec. stainless steel hose clips	Int. Ø, mm	Ext. Ø, mm
1140664	200	961669	32	41.5
1140665	285	961671	45	55
1140670	305	961672	50	61.5
1140666	310	961673	57	69
1140671	355	961674	63	75
888212	455	22274886	76	88
1140667	535	22274887	89	101
1140668	610	22274888	102	115
1140669	760	3817828	127	140
1140672	950	3595350	152	165
1140673	1200	21609813	205	217



Elbow coupling, wet exhaust systems

The elbow coupling provides an improved installation and reduces the risk of a kink forming in the exhaust hose.

Material: Stainless steel with pre-formed collar for hose connection.

Part no	Angle, degrees	Ext. Ø, mm
828256	45	45
828255	45	57
843287	45	89
872017	45	100
872024	90	100



Exhaust riser

An exhaust riser raises the level of the exhaust elbow. This is installed on vessels with engine installations at or below the water line. The riser reduces the risk of siphonage back into the engine via the exhaust system.

Part no	Height	Fits engine
3884165	100 mm/4"	D1-13, D1-20, D1-30, D2-40
40005141	150 mm/6"	4,3-5,7L SX/DPS
40005142	150 mm/6"	8,1L SX/DPS
3886142	75 mm/3"	4,3-5,7L SX/DPS
3888846	75 mm/3"	8,1L SX/DPS
3581031	—	MD2010-2040
861097	100 mm/4"	KAD42, KAD43, KAD44, KAD300
3862907	150 mm/6"	4,3-8,1L (inb.)

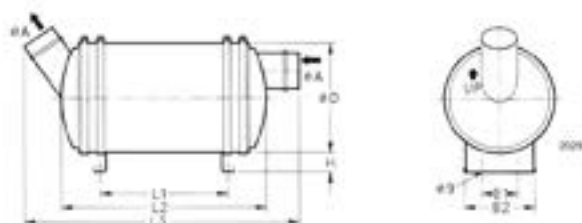

Silencer, wet exhaust systems

The silencer effectively silences engine exhaust noise with a minimum of back pressure. The silencer also functions as an effective water-lock. Its large capacity for cooling water eliminates the risk of water siphoning back into the engine when stopped. Adjustable mounting brackets make the silencer easy to install.

Material: Reinforced rubber with acid resistant stainless steel end pieces.

Part no	ØA	ØD	ØB1	ØB2	H	L1	L2	L3	Hose dia.
828064	45	165	60	112	30	208	334	440	45 mm
828837	45	165	60	112	30	208	334	440	45 mm a)
838327	57	165	60	112	30	408	535	645	57 mm
842768	89	220	90	140	40	370	500	665	89 mm
854760	100	218	90	114	40	375	450	500	100 mm a)

a) Horizontal exhaust exit suitable for installations with limited height.



Through-hull exhaust fitting

Through-hull exhaust fitting with drip-edge to prevent cooling water from discolouring the side of the hull. With pre-formed collar for hose connection. Supplied complete with hose clips.

Part no	Material	Ext. Ø, mm
828295	Aluminium	89
854754	Stainless steel	100
833738	Brass	45
831781	Brass	57

Exhaust temperature alarm, wet exhaust systems

The temperature alarm sensor is installed in the exhaust hose and transmits a signal to a warning lamp in the event of excessive exhaust temperatures as a result of water shortage.

Includes: Sensor, cables.

Part no	Fits engine
877773	MD2010-2040, D1-13-D2-75

COOLING SYSTEM

The cooling system is an extremely important part of the engine assembly. A correct working temperature contributes to a longer operational lifespan of the engine and improved fuel economy. It is also important from a safety aspect. With a correctly dimensioned and correctly installed cooling system, overheating of the engine, unnecessary stoppages and expensive repairs due to engine failure, can be avoided.

COOLING SYSTEMS CAN BE OF TWO DIFFERENT TYPES:

Sea water cooled (direct cooling), where sea water is directly pumped into the engine's cooling system and subsequently discharged via the exhaust system (wet exhaust systems) or via a separate discharge point for cooling water (for dry exhaust systems).

Fresh water cooled (indirect cooling) where the engine has its own closed loop cooling system similar to that of a motor car. The temperature of the engine coolant is reduced by being passed through a heat exchanger which is itself cooled by a supply of continuously pumped sea water. The sea water is discharged either via the exhaust, when used with a wet exhaust system, or via a separate outlet, when used with a dry exhaust system.

Freshwater cooling has a number of advantages compared to sea water cooling, these being:

- Better comfort, i.e. availability of domestic hot water and onboard heating. More extensive usage.
- The anti-freeze and anti-corrosion agents contained within the coolant permit all year running. Should it be required to totally decommission the engine, the coolant channels can simply be filled with inhibitors.
- Reduced engine wear as a result of higher running temperatures.
- Extended engine life due to better corrosion protection.

It is a relatively simple operation to fit a fresh water cooling system to a sea water cooled engine.

SEA WATER COOLING

1. Exhaust bend, wet type
2. Engine cooling galleries
3. Vacuum valve
4. Sea water pump
5. Sea water filter
6. Cooling water intake
7. Hose

FRESH WATER COOLING

1. Exhaust bend, wet type
2. Engine cooling galleries
3. Vacuum valve
4. Sea water pump
5. Sea water filter
6. Cooling water intake
7. Hose
8. Heat exchanger
9. Expansion tank
10. Hot water outlet
11. Hot water heater

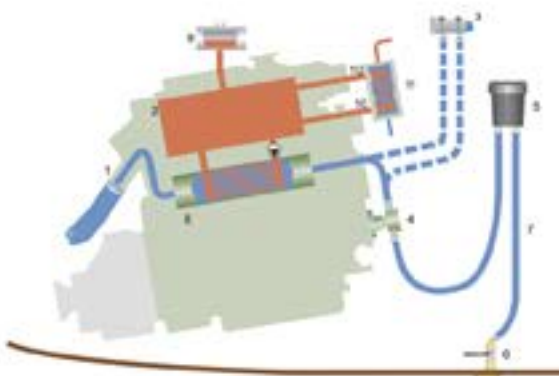
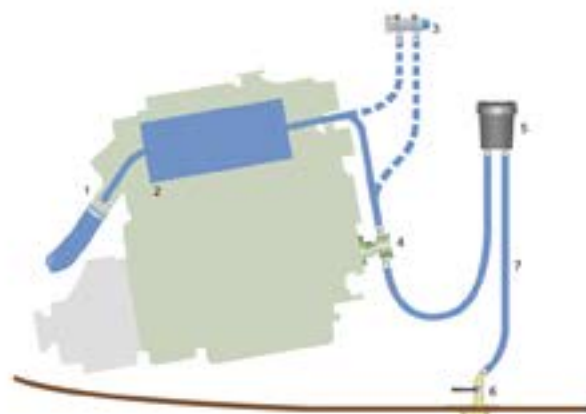

Vacuum valve

For vessels with an engine installation at or below the water line a vacuum valve should be installed. The valve prevents siphonage occurring through the seawater intake, resulting in water ingress to the engine.

Part no	Hose dia.
21662701	16 mm
21662702	19 mm
21662703	22 mm
21662704	25 mm



Seawater filter 32 mm

The seawater filter should be installed in the cooling system's suction line above the water line. The filter effectively separates any impurities from the seawater and contributes to extending the service life of the engine. The filter element is easy to clean.

Material: Plastic container and filter

Connection: In: 32 mm, Out: 32 mm

Height: 210 mm incl. hose connectors

Width: 130 mm

Depth: 130 mm

Rec. rubber hose: 1140664 (32 mm)

Part no
3583840



Seawater filter, heavy duty 50 mm

The filter has a large capacity suitable for use in extremely dirty or muddy waters. The filter element is easily cleaned and is covered with a transparent cover for ease of inspection.

Material: Plastic container and filter

Hose connection: Hose int. dia 50 mm

Height: 255 mm

Width: 220 mm

Depth: 200 mm

Volume: Approx. 2,7 litres

Rec. rubber hose: Part no. 1140670

Part no
21655254



Seawater filter, heavy duty 63 mm

The filter has a large capacity suitable for use in extremely dirty or muddy waters. The metal filter strainer is easily cleaned and is covered with a transparent cover for ease of inspection.

Material: Bronze casting with clear sight glass

Volume: Approx 5 liters

Hose connection: Hose int. dia 63 mm

Rec. rubber hose: Part no. 1140671

The kit contains: Filter, mounting brackets

Part no	Description
23226380	Seawater filter
21298806	Hose connection
961673	Hose clamp



Sea water filter cover

The transparent cover fits all seawater filters for D4 and D6 engines.

Part no
21400685



Hose adapters

For connection of seawater filter to cooling hoses of other diameters, cut adapter if necessary. Hose clamps for connection to filter included. Hose clamps for cooling hoses have to be ordered separately. One or two adapters are required for an installation.

Part no	Inner dia.	Outer dia.	Length
21951974	50 mm	32/38 mm	142/99 mm
21951975	32 mm	16/19 mm	87/62 mm



Expansion tank

A separate expansion tank for engine coolant can be installed in an easily accessible position and thereby make checking and filling of the system considerably easier. The tank is manufactured of a semi-transparent material to enable the checking of the coolant level.

Material: Plastic

Installation: Max 1.2 metres above the highest point of the engine.

Includes: Tank, pressure cap, fittings for installation.

Part no	Fits engine
3581427	2010-2040/MD22
3581297	MD31-42
3886264	D4-D6



Hot water outlet

A hot water connection is made to the engine cooling system which allows the hot coolant water to circulate through a water heater. The hot coolant heats up the water contained in the water heater. This then provides a domestic hot water supply.

Recommended hose for engine/water heater:

Hose, int. diameter 16 mm, part no. 952969

Recommended stainless steel hose clips: part no. 961665

Recommended hose for domestic supply:

Hose, int. diameter 12.7 mm, part no. 952968

Recommended stainless steel hose clips: part no. 961665

Part no	Fits engine	
861523	MD2010-20A, MD2030-40, D2-50, D2-55	
3862101	4.3GL, 5.0GL, 5.7GX	a)
860706	AD31/41, KAD300/43/44, KAMD300/43, TAMD31/31S/41	b)
3581632	TAMD22, TMD22, MD22	
3583734	KAD32	
3862102	8.1Gi, 8.1GX	c)
21177136	D9, D11	
3818029	8.1GiE/Gi/GXiE/GXi	
40005445	3.0GLP-J	
21145632	D4, D6	
21527832	4.3GL/GXiE/GXi, 5.0GX/C/GXiCE/GXiE/GXi, 5.7G/GiC/GiCE/GiE/GXi-CE/GXiE/GXi	
3588682	D3-130-190A	
3841173	D1-13-D2-40	

a) Only for raw water cooled engine. 4.3GL - A, 4.3GX - A, B, BF, 5.0GL - A, B, 5.0GX - A, B, BF, 5.7GL - A, B, 5.7Gi - A, B, BF, 5.7GX - B, C, CF.

b) Also for KAD/KAMD42 engines

c) Only for raw water cooled engine. 8.1Gi - B, BF, 8.1GS, 8.1GX - A, AF, DPX375 - B, BF, DPX420 - B, BF.



Freshwater cooling kit

Part no.	Fits engine
40005807	4.3GL-J, 5.0GL-J
40005446	4.3GXIE-M, 4.3GXJ, 5.0GXIE-M, 5.0GXJ, 5.7G-300-J, 5.7GXIE-300-M, 5.7GXIE-M, 5.7GXJ
21403116	5.0 GXIC-J, 5.0 GXIC-JF, 5.7 GIC-300-J, 5.7 GIC-300-JF, 5.7 GXIC-J, 5.7 GXIC-JF, 5.7 GICE-300-J, 5.7 GICE-300-JF, 5.7 GXICE-J, 5.7 GXICE-JF, 5.7 GXICE-300-M, 5.7 GXICE-300-MF, 5.7 GXICE-M, 5.7 GXICE-MF
21403117	8.1 GIC-400-J, 8.1 GIC-400-JF, 8.1 GIC-400-G, 8.1 GICE-400-J, 8.1 GICE-400-JF, 8.1 GICE-400-M, 8.1 GICE-400-MF, 8.1 GICE-400-P, 8.1 GICE-400-R



Cooling water intake

The cooling water intake is a through-hull fitting with strainer, installed through the bottom of the hull. For motor boats the strainer should be directed forward. Once under way, the seawater is forced up into the system. However, for sailing boats, the strainer should be directed towards the rear of the boat in order to prevent seawater being forced into the system when under sail with the engine shut down. When a motor boat is being towed, the shut-off valve must be closed.

Includes: Through-hull fitting with strainer, fittings for pipe connection, shut-off valve, hose clips.

Part no	Internal hose diameter
861495	19 mm
861496	19 mm
1140129	32 mm
3587668	38 mm
1140127	50 mm



Rubber hoses

Volvo Penta rubber hoses are specifically designed for use with the engine's cooling system and are designed to withstand both suction and pressure.

Part no	Min. bend radius mm	Rec. stainless steel hose clips	Int. Ø, mm	Ext. Ø, mm
952968		961665	12.7	20.6
952969		961665	16	23.8
952970		961666	19	27
952971		961667	22	30.2
952972		22274884	25.4	33.3
1140664	200	961669	32	41.5
1140670	305	961672	50	61.5
1140671	355	961674	63	75

NEUTRA-SALT

Neutra-Salt engine flushing kit

Designed for both freshwater- and saltwater-cooled engines that have an engine-driven sea-water pump.

The Neutra-Salt Engine Flushing System is available for installation on all inboards and sterndrives. This system is designed for both freshwater- and saltwater-cooled engines that have an engine-driven sea-water pump. As a saltwater boater, you are continually challenged by the corrosive effects of salt - both inside and outside your engine - particularly when the boat is sitting unused in the water. Now, with the installation and use of the Neutra-Salt Engine Flushing System, you have an effective and simple solution to combat internal corrosion and help extend the life of your engine.

Benefits of our flushing system:

- Flushes your engine while the boat is in the water -there is no need to trailer your boat or hook up to a freshwater supply in order to flush and protect your engine.
- Helps protect your engine from saltwater damage.
- Helps prevent corrosion by removing salt deposits, leaving a protective corrosion inhibitor on all metal surfaces, including: Power-steering and oil cooler, engine block, exhaust manifold and risers, thermostat housing, circulating and raw-water pumps.
- Installs easily and operates smoothly.

Kit includes:

0.95 litre of Neutra-Salt motor flushing concentrate, 2.85 litre reservoir with mounting bracket, eight feet of hose, brass sea-water inlet tee fitting, connecting hose for power-steering cooler, hose clamps, rocker switch, "Flush" switch, wiring harness with fuses, and solenoid.

How our flushing system works:

1. To operate, simply engage the "Flush" switch by pushing and holding the dash-mounted switch for 45 seconds while running the engine at idle speed, making sure the engine has an adequate supply of sea water.
2. Once the Flush switch is engaged, the Neutra-Salt concentrate solution will be injected into the cooling system, leaving a corrosion-inhibiting coating on all metal surfaces, thereby neutralizing the salinity of incoming seawater.
3. Before disengaging the Flush switch, you must turn off the engine. For best results, use the Neutra-Salt Engine Flushing System after every trip outing. Boat owners will typically get 10 to 15 flushes before a refill is needed.

Our exclusive Neutra-Salt Concentrate offers many benefits:

It flushes motors, dissolves salt and salt deposits, prevents rust and corrosion (includes a corrosion inhibitor which leaves a protective coating on all metal surfaces), extends the life of metal surfaces exposed to saltwater, and removes salt from engines, fishing equipment, scuba gear, boats, trailers, etc.



Neutra-Salt Concentrate

Our exclusive Neutra-Salt Concentrate offers many benefits:

Flushes motors.

Dissolves salt and salt deposits.

Prevents rust and corrosion (includes a corrosion inhibitor which leaves a protective coating on all metal surfaces).

Extends the life of metal surfaces exposed to saltwater, and removes salt from engines, fishing equipment, scuba gear, boats, trailers, etc.

Part no	Quantity
21687793	Quart/0.95 l
21687796	Gallon/3.8 l

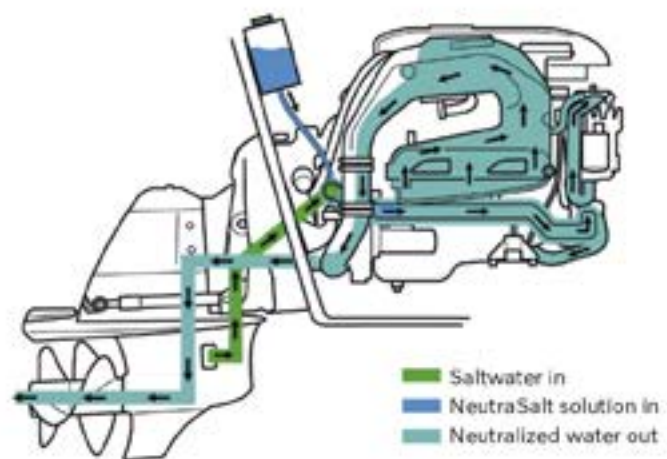

Part no	Description
21733731	Kit for engine with 1" or 1 1/4" water inlet hose

POWER TAKEOFF

An extra alternator and an efficient distributor greatly increase your onboard power supply. And with the power takeoff your engine can power a cooling compressor, hydraulic pump etc.



Universal bracket

The front mounted universal bracket enables installation of extra equipment such as cooling compressor or hydraulic pump. The kit includes bracket and fittings.

Part no	Fits engines	
3584501	D4, D6	
3581049	MD2010A-D, MD2020A-D, MD2030A-D	a)
3583586	MD2040A, MD2040B, MD2040C, MD2040D, TAMD22, TMD22, MD22, D2-55 A, D2-55 B, D2-55 C, D2-55 D, D2-55 E, D2-55F, D2-60, D2-75 A, D2-75 B, D2-75 C, D2-75F	b)
3884549	D1-20 A, D1-20 B, D1-20F, D1-30 A, D1-30 B, D1-30F	
3884550	D2-40 A, D2-40 B, D2-40F	
3809865	D3	

a) Pulley and drive belt ordered separately. For engines with S-drives, see information in selection charts.

b) Pulley and drive belt ordered separately. Adapter kit, 3583805, needed with S-drive installations.

Extra pulleys

Auxiliary equipment driven by the drive belt on the crankshaft of the engine increase the load on the crankshaft. It is thus important that the axial location of the pulley on the crankshaft and the location of the equipment in relation to the crankshaft are suited to the extra power requirements of the extra equipment. Maximum power supplied depends on the alignment of the belt, the belt type and the engine type.

Part no	No. of grooves/ pulley	Outer mm	V-belt groove	Length, mm
3809925	3	165	HC50	90
3809926	1	165	PK6	90
3581053	1	120	HC50	19

ELECTRICAL SUPPLY

Today's boats are equipped with more and more electrically powered accessories for both comfort and safety.

Power for lighting, radio transmitters, TV, stereo equipment, fans, heating, etc., drain battery power. As the charging of batteries takes a relatively long time, an extra charge alternator and an extra battery are good investments.



Alternator kit, including alternator

Part no	Capacity	Fits engine	Note
22821293	12V/115A	D8	
22821286	24V/110A	D8	
21173893	24V/80A	D9, D11	
21173894	12V/115A	D9, D11	

Mounting kit, excluding alternator

Part no	Capacity	Fits engine	Note
3583573	12V/60A alt. 24V/40A	D2-55A, D2-60, D2-75A	Only for D2-55/D2-75 generation A. Also order pulley kit 3583468 and cable kit 3583574, Alternator 12V/60A: 873770, Alternator 24V/40A: 872927
21384685	12V/115A alt. 24V/80A	D2-55, D2-60, D2-75	Not for D2-55/D2-75 generation A, Alternator 12V/115A: 3840181 Alternator 24V/80A: 3840183
21281679	24V/110A	D2-55, D2-60, D2-75	For large casing, 4" dual foot saddle mount alternator (SAE J180 mount)
3884494	12V/60A alt. 24V/40A	D1-20	Also order cable kit 3583574, Alternator: 873770 alt. 872927
3884493	12V/60A alt. 24V/40A	D1-30, D2-40	Also order cable kit 3583574, Alternator: 873770 alt. 872927
21268949	12V/130A, 24V/75A, 24V/110A	D3	For large casing, 4" dual foot saddle mount alternator (SAE J180 mount)
3889549	12V/115A alt. 24V/80A	D4, D6	For EVC-A to EVC-C3. Can not be combined with servo steering. Alternator 12V/115A: 3840181, Alternator 24V/80A: 3840183
22448959	12V/115A alt. 24V/80A	D4, D6	From EVC-D. Can not be combined with servo steering. Alternator 12V/115A: 3840181, Alternator 24V/80A: 3840183

Alternator

Part no	Capacity	Fits engine
873770	12V/60A	D1-20, D1-30, D2-40, D2-55A, D2-75A
872927	24V/40A	D1-20, D1-30, D2-40, D2-55A, D2-75A
3840181	12V/115A	D2-55, D2-75, D4, D6
3840183	24V/80A	D2-55, D2-75, D4, D6



Charge distributor

The charge distributors are specially adapted for Volvo Penta alternators. Two independent battery circuits can be charged at the same time. The starter motor battery will always be charged, even when onboard power consumption has been great and the second battery is flat.

For alternators 12-24 V/50-60 A. Equipped with sensor for directly monitoring the voltage of the battery in use.

Part no	Description
873120	6-50 V/ Max 70 A
3840597	6-50 V/ Max 160 A
3589487	12 V/Max 200 A

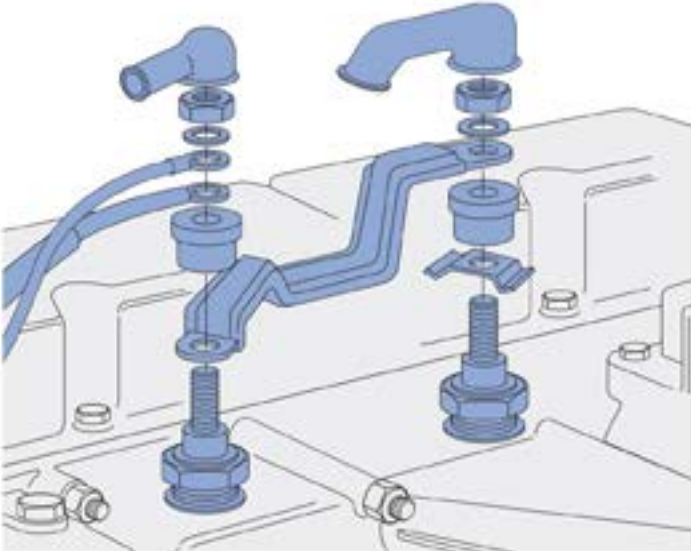

Air pre-heater kit

For engines starting in low ambient temperatures.

The kit contains: 2 glow plugs that are installed in the intake pipe. The glow plugs are activated with the ignition key via a relay to warm up the intake air.

Warning! Never use start spray/gas on engines equipped with glow plugs.

Part no	Fits engine
874117	TMD31/41, TAMD31/41, AD31/41



1



2

Main switch

Single pole switch in corrosion resistant material for marine use. With removable switch control. Breaks the power circuit for all electrical equipment and is thereby particularly useful in terms of comfort, safety and theft.

Image	Part no	Cont. load	Max load	Working load
1	1140319	150 A	1000 A for 5 s	450 A for 5.5 min
2	22172491	300 A	2500 A for 5 s	-

PROPELLER SHAFT COUPLING

The Volvo Penta two-piece rigid propeller shaft coupling is designed to make installation much easier and less time consuming. It requires no costly machining and thanks to the two-piece conic design, the coupling is perfectly centred onto the propeller shaft. This is essential for minimal vibration, low noise and a better boating experience.

No machining required

No costly machining for tapering and keyway-cutting is required. Just cut the propeller shaft to the correct length and fit the coupling cone. Secure it to the coupling flange with the bolts provided and the coupling is complete. The shaft coupling provides a high torsional hold without causing shaft damage.

Perfect central alignment

The two-piece conic design gives the coupling perfect central alignment properties and also provides an absolute distortion free coupling fit. Altogether this makes it easier to achieve a correctly aligned driveline, essential for minimal vibration and low noise.



Component guide

The Volvo Penta two-piece rigid propeller shaft coupling is delivered complete with bolts, nuts, washers and installation instructions.

Engine	Gearbox	Part no. coupling for shaft 25 mm*	Part no. coupling for shaft 30 mm*	Part no. coupling for shaft 35 mm*	Part no. coupling for shaft 40 mm*
D1	MS10, MS15	21827365	21827366		
D2-40	MS10, MS15		21827366		
D2-55 / D2-75	MS25		21827366		
D2-55 / D2-75	HS25		21820009	21820010	23310037
D3, D4, D6	HS25, HS45, HS63				23310037

* Required shaft tolerance: h9 (+0.0 -0.050)

Dimensions

The shaft coupling is made from high grade 1018 steel (E 235 i ISO) with zinc-nickel coating and sealer. With its compact design the shaft coupling is also perfect for installations where space is limited. Suitable if you want to upgrade your boat driveline.

Part no. coupling	L mm (inch)	D mm (inch)	Weight kg (lb)
21827365	63 (2.48)	102 (4.02)	3,1 (6.8)
21827366	63 (2.48)	102 (4.02)	3,0 (6.6)
21820009	63 (2.48)	127 (5.00)	4,9 (10.6)
21820010	67 (2.64)	127 (5.00)	4,8 (10.6)
23310037	67 (2.64)	127 (5.00)	4,7 (10.4)



FEATURES AND BENEFITS:

- Simplified installation and alignment
- Less vibration and noise
- No machining required
- Two-piece conic design
- Perfect central alignment
- High torsional hold without shaft damage
- Compact dimensions, low weight
- Virtually maintenance free
- Easy to disconnect propeller shaft, without re-adjustment
- Integrated counterhold
- Better onboard comfort

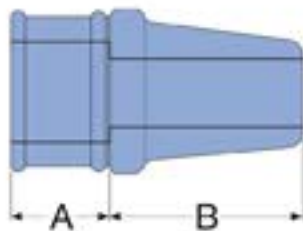

Rubber packing box

Moulded packing box for effective lubrication/sealing. Simple, time saving installation and compact size. Minimal maintenance work – grease every 200 hours or once a year. The packing box is specifically dimensioned for Volvo Penta propeller shafts and sleeves. For effective lubrication it is essential that the packing box bearings are water-lubricated at all speeds. Supplied complete with installation tools and grease tube.

Part no	A, mm	B, mm	Shaft Ø, mm	Ext. dia. shaft sleeve mm ¹⁾
828254	36	66	25	42
828422	36	72	30	48
828526	36	82	35	54
828527	36	82	40	60
3819722	36	92	45	64
3819723	36	92	50	70
3819724	36	66	1"	1 3/4"
3819725	36	75	1 1/4"	2"
3819726	36	82	1 1/2"	2 1/4"
3819727	36	92	1 3/4"	2 1/2"
3819728	36	92	2"	2 3/4"

¹⁾ Diameter tolerance +0.5 –0.3 mm. The distance between bearing points must not exceed 1500 mm.



Key for older shafts

A new key is now available for older types of shaft with a 10 mm key slot to make them suitable for new ISO standard bronze propellers.

Part no	b, mm	B, mm	h, mm	H, mm	L, mm	Shaft Ø, mm
3580804	8	10	3.5+0.1	6+0.1	58	30
3580805	10	12	3+0.1	6+0.1	80	40

Rubber bearing

Water-lubricated rubber bearing for stern and support bearings.

Part no	A, mm	B, mm	Shaft Ø, mm
812914	100	38	25
812916	127	44	30
827175	140	48	35
828131	160	54	40

Lock washer for propeller shaft nuts

Note: V9338 = Week 38, year 1993.

Part no	Shaft Ø, mm	
873475	25	a)
828383	25, 30	b)
873488	30	a)

a) Lock washer for propeller shafts manufactured after V9338.
b) Lock washer for propeller shafts manufactured before V9338.



Propeller shaft nut anodes

Sacrificial zinc nut anodes for Volvo Penta propeller shafts.

Part no	Propeller shaft Ø	Thread (T)
828140	40 mm / 45 mm	1"
833913	30 mm	3/4"
833915	35 mm	7/8"
873411	25 mm	M16
873412	30 mm	M20
873413	35 mm / 40 mm	M24
873415	45 mm	M30



SILENT SHIFT

The Volvo Penta Silent Shift technology for Aquamatic stern-drives provides smooth and soundless shifting. This improved level of comfort is particularly evident in low-speed maneuvering and when docking. If you have a D3 or gasoline engine, you

can take advantage of this technology. All it takes is changing out the upper gear unit on your existing drive, which can easily be done by an Authorized Volvo Penta dealer.

SX, DPS and FWD drives

The Silent Shift upper gear unit includes a multi-plate clutch which replaces the existing upper gear with traditional cone clutch on SX, DPS and FWD Aquamatic stern-drives. The new Silent Shift upper gear unit is mated with the lower gear of your existing drive and carries the 2 year Parts & Accessories warranty – including the labor – when installed by an authorized Volvo Penta dealer.

Silent Shift upper gear

Part no	SX ¹⁾	DPS ²⁾	FWD ³⁾
23290085	1:79, 1:89, 1:97, 2:18	2:32	2:32
23290086	1:51, 1:60, 1:66	1:78, 1:95	1:95
23290087	—	2:14	2:14

1) from SX-A and newer 2) from DPS-A and newer 3) All versions





Two versions

The sound absorbents are sold in sheets of 500 mm x 1000 mm (20 in x 40 in), they are easy to handle both in transport and when mounted. They are available in three thicknesses, 20, 30 and 50 mm, and can easily be cut to shape with a sharp knife. The sheets come in two versions, self-adhesive and nonadhesive.

Fire resistant material

Sound Absorbent Panels are approved for installation in boats to be CE marked according to EU Directive 94/25/EC. The material is treated with a fire-resistant formula and withstands temperatures up to max. 200°C/390°F. The material is covered with an oil resistant foil that easily could be cleaned from any oil spray etc.

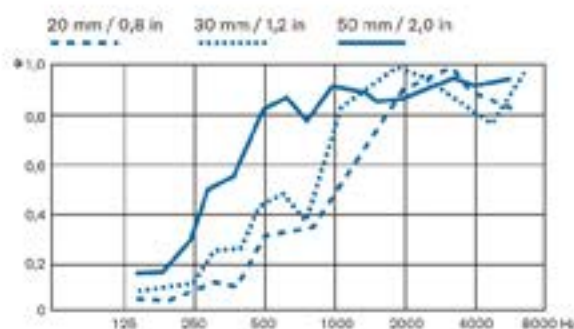

Sound absorption diagram according to DIN 52215

Optimum performance is reached at $\alpha=1.0$. Depending on the engine noise characteristics (100-8000Hz) select the appropriate thickness of Sound Absorbent panel.

SOUND ABSORBENT PANELS

The sound absorbents have a very good isolating and absorbing effect with a density of 100 kg/m³ (6,24 lb / ft³), and are well adapted to the noise frequency and noise level of marine engines (see diagram). They are made of recycled foam, which has a combination of weight and porosity that both insulates and absorbs.

Features:

- Made of recycled polyurethane foam.
- Density of 100kg/m³ / 6,24lb/ft³.
- Protection film of aluminium foil.
- Fire proof reg: ISO3795 (FMVSS302).
- Temperature resistance: Max. 200°C / 390°F.
- Oxygen index: 24% according to ASTM D2863-91 and fulfills ISO 4589-3.

Sound absorbent panels

Part no	Dimension	Rear side	Sound absorbent panel
41103800	500 x 1000 mm	Non-adhesive	20 mm
41103801	500 x 1000 mm	Non-adhesive	30 mm
41103802	500 x 1000 mm	Non-adhesive	50 mm
41103803	500 x 1000 mm	Self-adhesive	20 mm
41103804	500 x 1000 mm	Self-adhesive	30 mm
41103805	500 x 1000 mm	Self-adhesive	50 mm



Best result

To achieve the best possible result, it is important that you fit the sheets properly. The joins must be as tight as possible and covered with foil tape to avoid noise leakage or penetration of water, which could be absorbed by the material. For convenient mounting you can use Sound Insulation Hangers.

Foil tape

Part no	Aluminium tape	Rear side	Length
41103806	Roll	Self-adhesive	5 m
41103809	Roll	Self-adhesive	50 m

AIR HEATER

The air heater extracts heat from the engine's cooling system, which would otherwise be wasted, and transfers it into the cabin. A fan circulates air through a heat exchanger. The air heater makes it possible to make use of the engine closed-circuit cooling system without additional water pipes and radiators.

Air heater

Product data:

Output: 10 kW/5 kW

Power supply: 12 V/24 V

Capacity (free flow): 550m³/330m³/hour at max. speed

Fan: 3 speed

Casing: Stainless steel

Heat exchanger: Copper/Brass

Weight: 6.6 kg/5.1 kg

Dimensions: 370 x 160 x 236 mm/230 x 160 x 236 mm

Fan type: Radial

Water connection: 16 mm

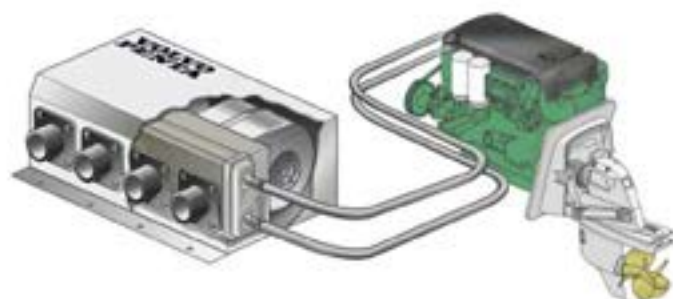

Four outlets are supplied that can be connected with air hoses. The standard outlets are 55 mm diameter. The airflow can be set at three different speeds.

The air heater is highly efficient and can be installed vertically or horizontally. Its compactness makes it easy to install almost anywhere. The selection of materials; stainless steel for the casing and copper/brass for the heat exchanger, ensures long service in a harsh onboard atmosphere.

The air heater comes in two sizes; 5 and 10 kW. Available for 12 V or 24 V supply, it consumes very little power. Its low noise level is another advantage. The air heater can be installed above the engine and any air trapped in the coolant can be released through a separate bleed valve.

Optional extras include air hoses, hose connections and various types of air valves.



Air heater

Part no	Effect	Voltage	Outlet diameter
21621753	10 kW	12 V	55 mm
21621754	10 kW	24 V	55 mm
21621751	5 kW	12 V	55 mm
21621752	5 kW	24 V	55 mm
21621755	10 kW	12 V	60 mm

Air heater - accessories

Part no	Description
21656846	Hose connector kit, 50 mm
21656848	Hose connector kit, 60 mm
21656849	Hose connector kit, air intake, 80 mm
41103307	Switch
21656851	Nozzle, adjustable, black 50 mm
21656852	Nozzle, adjustable, black, 55 mm
21656853	Nozzle, adjustable, black, 60 mm
21656854	Hose, 50 mm (sold per meter)
21656855	Hose, 55 mm (sold per meter)
21656856	Hose, 60 mm (sold per meter)
21656857	Hose, air intake, 80 mm
21656847	Hose connector kit, 55 mm
41103316	Y-connector, 80 mm
21656860	Y-connector, 60 mm
21656859	Y-connector, 55 mm
41103329	High-flex hose, 55 mm



EXTENDED COVERAGE

Volvo Penta International Limited Warranty covers your complete engine package for 2 years, and major components for an additional 3 years. With the Marine Leisure Extended Coverage program, you will keep full protection for years 3-5 for added peace of mind.

The Marine Leisure Extended Coverage is purchased when the engine package is ordered or within 6 months from the date of warranty registration.



Learn more about Extended Coverage.
Talk to your Volvo Penta dealer or
go to volvopenta.com



REPOWERING

Installing a new engine is an investment in a better boating experience. With the right engine, you'll enjoy increased reliability, better performance and improved fuel economy, along with a cleaner, quieter and more comfortable ride. Changing to a new engine will also increase the value of your boat.

Volvo Penta offers a wide range of engines – from 12 to 1000 hp – to suit your needs and bring new life to your boat. In addition, we offer several smart repowering kits, designed to make the transition to a new and modern engine easier and more cost effective.



THE D3 REPOWERING KIT

Replace your old diesel or gasoline engine with a new, modern Volvo Penta D3 diesel engine – all while keeping your current drive.

The D3 repowering kit consists of all components needed for a perfect match between the new engine and your existing drive. The kit provides full EVC functionality including electronic shift and throttle for smooth and precise control. In addition, it gives you access to a wide range of accessories, making your boating experience easier, safer and more enjoyable.

Read more about Volvo Penta D3 at www.volvopenta.com

Drive and engine combinations

The table shows various drive and engine combinations that are available with the D3 Repowering Kit. Always consult your Volvo Penta dealer about the best engine option for your boat and drive.

Drive	D3-140	D3-170	D3-200	D3-220
AQ290	•	•	•	•
AQ290A	•	•	•	•
AQ290-DP	•	•	•	•
AQ290A-DP	•	•	•	•
SP-A, -A1, -A2	•	•	•	•
SP-C	•	•	•	•
SP-E	•	•	•	•
DP-A, -A1, -A2	•	•	•	•
DP-B, -B1	•	•	•	•
DP-C, -C1	•	•	•	•
DP-D, -D1	•	•	•	•
DP-E	•	•	•	•



The D3 diesel engine connected to a classic AQ290 drive using the D3 repowering kit.

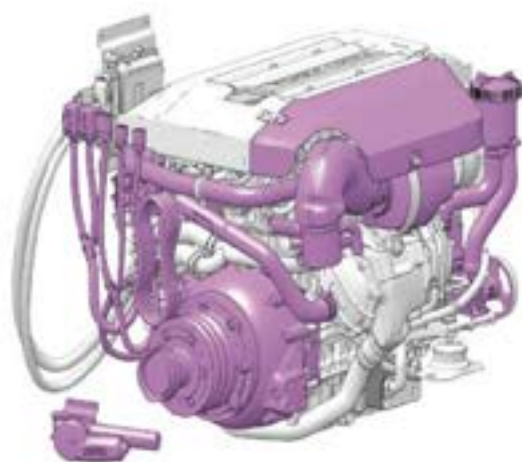

D3 repowering kit. All required components are included, such as adapter ring, exhaust riser, heat shield for turbo and riser, engine cover, installation instructions etc.

Whatever your needs are, your Volvo Penta dealer has the expertise and special tools required to evaluate your repowering options and help you to make the best choice for your boat.

Planning well ahead with a competent partner is the key for a successful repowering.



D1/D2 REPOWERING KIT

Give your boat a new life by replacing your old engine with a new Volvo Penta D1 or D2 diesel engine. The D1/D2 Repowering Kit will make it easier to install the new engine and will cause minimal impact to your existing engine bed.

With a new Volvo Penta engine installed, you will experience the advantages of improved maneuverability, quieter operation, increased performance and charging capacity. You'll also boost the value of your boat.

The D1/D2 Repowering Kit is available for engines in both shaft and Saildrive installations.



MADE TO MATCH WITH EXISTING ENGINE BED

The D1/D2 Repowering Kit contains a unique set of components required for the specific engine replacement. The brackets are designed to perfectly match the new engine to your existing engine bed, minimizing time consuming fiberglass work. The installation will ensure low vibrations and a quiet boat operation.

Depending on your engine series, the D1/D2 Repowering Kit consists of: Brackets, screws, nuts and installation instruction. Below you'll find possible engine replacements available with the D1/D2 Repowering Kit. Please contact your Volvo Penta dealer for the best repowering options for your boat.

Repowering with Saildrive (from Volvo Penta engine)

Kit no	Note	Current engine	New engine
22410366		MD5	D1-13/20/30
22410368		MD6/7/11/17	D1-13/20/30
22410370		MD17	D2-50/60/75
22410372	Engine bed modifications needed	MD21	D2-50/60/75
22410374		2001	D1-13/20/30
22410376	Engine bed modifications needed	2002/3(T)	D1-13/20/30
No kit needed		MD2010/2020/2030	D1-13/20/30
22410380		MD2020/30	
22410382		MD2040	
No kit needed	Minor engine bed modifications needed	MD22 L/P & TMD22	D1-13/20/30

For above installations the existing Saildrive needs to be replaced, except for the 1205 saildrive when repowering to D1-13/20/30. Then it's possible to add the kit 22567193 and keep the 1205.

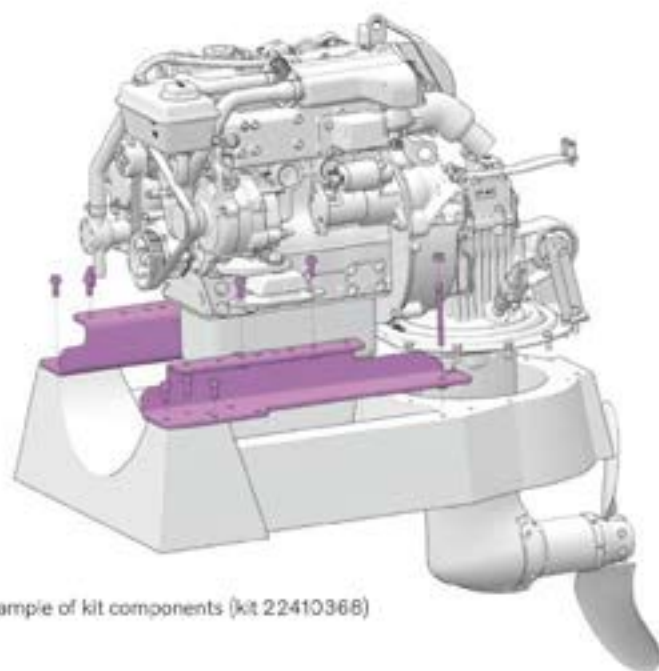

Example of kit components (kit 22410368)

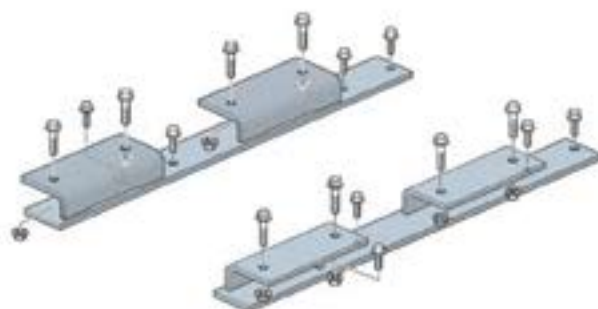

Example of kit components (kit 23059553)

Repowering with gearbox (from Volvo Penta engine)

Kit no	Note	Current engine	New engine
No kit needed	New gearbox MS15L	MD1/2	D1-13/20/30
22594876		MD3	D1-13/20/30
Tool 22340457	Engine bed modifications needed	MD5A-B	D1-13/20/30
22567201		MD6/7A-B	D1-13/20/30
22567203		MD11C-D	D1-13/20/30
Tool 22340457	Engine bed modifications needed	MD17C	D1-13 to D2-75
Tool 22340457	Engine bed modifications needed	MD21A-B	D2-50/60/75
22567205		2001/2/3(T)	D1-13/20/30
No kit needed		MD2010	D1-13/20/30
No kit needed		MD2020/2030	D1-13/20/30
No kit needed		MD2040	D2-50/60/75
No kit needed		MD22L-P & TMD22	D2-50/60/75

For above installations, the gearbox needs to be replaced.

Repowering with Salsdrive (from Yanmar engine)

Kit no	Note	Current engine	New engine
23059555	Bed 370 mm	Yanmar SD20/25	D1-13/20/30
23059557	Bed 420/470 mm	Yanmar SD60	D2-50/60/75

For above installations the existing Salsdrive needs to be replaced.

Repowering with gearbox (from Yanmar engine)

Kit no	Note	Current engine	New engine
23059549		1GM / 1GM10	D1-13/20/30
23059551		2GM / 3GMD / 3GM	D1-13/20/30
23059551		2QM15 / 2GM20	D1-13/20/30
23059551		3YM30 / 3YM20 / 2YM15	D1-13/20/30
23059551		3HM	D1-13/20/30
23059553		YSEB	D1-13/20/30
23065809	Order two. Tool 22340457 needed	4JH45-KM35P / 4JH45-ZF30M	D2-50/60/75
23065809	Order two. Tool 22340457 needed	3QM30 / 3QM30H / 3QM30Y / 3QM30F	D1-30

For all installations the gear box must be replaced. All repowering kits for Yanmar are designed for straight (lined) gear box installation.

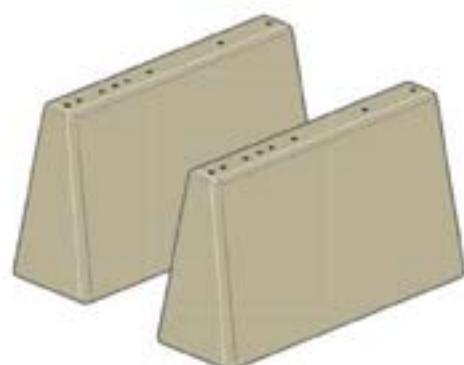

Beam 23065809 (order two)



Tool 22340457

PROPELLERS



THE ART OF PERFORMANCE

Volvo Penta propellers are an engineering art form. Behind the slightest curve, smoothest contour and tightest angle is a state-of-the-art design process based on years of experience. We know propellers, but most importantly we develop the entire

driveline. That's how we are able to convert power into real performance that you can feel on the water. It is this performance that leads to greater boating pleasure while contributing to the long-term health of your driveline.



2

Double your warranty. Genuine Volvo Penta propellers are covered by our standard 12 month warranty. Have them supplied and installed by an authorized Volvo Penta dealer and we'll extend your warranty to 24 months – including the labor.

The only way forward. For Volvo Penta, propellers will always be designed as a part of a complete propulsion system. It's the only way. Whether you have a powerboat or sailboat, there is a genuine Volvo Penta propeller designed entirely for your needs.

DUOPROP PROPELLERS FOR AQUAMATIC

Launched in 1982, Volvo Penta showed the marine industry that twin counter-rotating propellers could produce unparalleled thrust, straight and true tracking along with faster acceleration – a completely new boating experience.

DPH DRIVES

Type G – Nibral Duoprop propellers

The patented blade geometry provides optimal interaction between front and rear propellers for outstanding efficiency and smooth and comfortable operation. Complete with shock-absorbing rubber bushing and galvanic isolation makes it perfectly matched for the DPH-drive.

DIM	Set	Front	Rear	DIM	Set	Front	Rear
G2	—*	22898622	22898632	G7	—*	22898627	22898637
G3	—*	22898623	22898633	G8	—*	23795438	22898638
G4	—*	22898624	23795444	G9	—*	22898629	22898639
G5	—*	22898625	22898635	G10	—*	22898630	22898640
G6	—*	22898626	22898636				

* Type G propeller sets are replaced by either type H propeller sets, or individually sold type G front and rear propellers.



DPH AND DPI DRIVES

Type H – Stainless steel Duoprop propellers

Designed to capture the tremendous torque from the new generation D4 and D6 engines. The patented blade geometry of the Type H propellers provides optimal interaction between front and rear propellers, for outstanding efficiency and smooth and comfortable operation. The large blade area provides maximum grip and maneuverability. Made of high-strength stainless steel alloy for excellent strength and durability. Complete with shock absorbing rubber bushing and galvanic isolation makes it perfectly matched for the DPI and DPH-drive.

DIM	Set	Front	Rear	DIM	Set	Front	Rear
H2	22754002	22753972	22753982	H7	22754007	22753977	22753987
H3	22754003	22753973	22753983	H8	22754008	22753978	23623068
H4	22754004	23623054	23623064	H9	22754009	22753979	22753989
H5	22754005	23623055	22753985	H10	22754010	22753980	22753990
H6	22754006	23623056	23623066				



Changing from type G propellers to type H propellers on DPH drives

The sizing remains the same, ie a G6 propeller corresponds to an H6 propeller. Should you need additional guidance on which propeller best suit your needs, contact your Volvo Penta dealer.

Note! The propeller cone must be replaced to fit type H propellers. See part number to the right. Do not mix Type G and H propellers. Always use propellers of the same type and size on the drive (or on both drives in twin installations).



Propeller cone kit for type H propellers. P/N 23000185

Line cutter for DPH and DPI drives with type H propellers

The line cutter is an easy to install accessory that provides additional protection for your drive. It is designed to cut through ropes, fishing lines, plastic bags and nets before they can enter between the propellers and possibly cause damage to the propeller shaft sealing. The line cutter is installed between the propellers using the existing propeller nut.

Fits	Part No	Material
Type H propellers**	22827022	316 Stainless steel

**The line cutter is included as standard on DPI drives.



DPS DRIVES

Type I and IH – Aluminum Duoprop propellers

The patented blade geometry and large active propeller diameter provide optimal performance and fuel efficiency over the entire speed range as well as smooth running, excellent grip and maneuverability. Squeeze casting and special high-strength aluminum alloy makes them stronger and more durable than traditional die-cast propellers. Four layers of paint ensure excellent anti-corrosion performance. Type I has straight splines, type IH has helical splines.



Note! Always use type F or FH stainless steel propellers in engines exceeding 240 hp or capable of speeds above 38 knots (45 mph). See next page.

Type I for DPS, DPS-A (straight splines)

DIM	Set	Front	Rear	DIM	Set	Front	Rear
I 2	21258482	21260642	21657162	I 7	21258487	21260647	21657167
I 3	21258483	21260643	21657163	I 8	21258488	21260648	21657168
I 4	21258484	21260644	21657164	I 9	21258489	21260649	21657169
I 5	21258485	21260645	21657165	I 10	21258490	21260650	21657170
I 6	21258486	21260646	21657166				

Type IH for DPS-B (helical/spiral splines)

DIM	Set	Front	Rear	DIM	Set	Front	Rear
IH 2	21661942	21661902	21661922	IH 7	21661947	21661907	21661927
IH 3	21661943	21661903	21661923	IH 8	21661948	21661908	21661928
IH 4	21661944	21661904	21661924	IH 9	21661949	21661909	21661929
IH 5	21661945	21661905	21661925	IH 10	21661950	21661910	21661930
IH 6	21661946	21661906	21661926				

Upgrade from type D propellers to type I propellers

To ensure the best performance for your boat, consult your Volvo Penta dealer for advice on the right propeller size for your drive and engine. **Note!** Do not mix Type D and I propellers. Always use propellers of the same type and size on the drive (or on both drives in twin installations).

Type D – Aluminum Duoprop propellers for DPS, DPS-A (straight splines)

Type D propeller sets are replaced by type I propeller sets. However, Type D propellers (front and rear) are sold individually as spare parts.

DIM	Set	Front	Rear	DIM	Set	Front	Rear
D 0	—	3851420	3851440	D 5	—	3856345	3856355
D 1	—	3851421	3851441	D 6	—	3856346	3856356
D 2	—	3851422	3851442	D 7	—	3856347	3856357
D 3	—	3851423	3851443				



DPS DRIVES

Type F and FH – Stainless-steel Duoprop propellers

This is the perfect upgrade for enhanced performance, strength and durability. It provides better acceleration and higher top speed due to greater strength and thinner blades - versus a comparable aluminum propeller. The high-strength stainless steel adds excellent durability and corrosion resistance. Complete with shock-absorbing rubber bushing and galvanic isolation makes it perfectly matched for the DPS-drive and the ultimate choice for demanding boaters. Type F has straight splines, type FH has helical (spiral) splines.



Type F for DPS, DPS-A (straight splines)

DIM	Set	Front	Rear	DIM	Set	Front	Rear
F 2	3857583	3857557	3857558	F 6	3851496	3851466	3851476
F 3	3857564	3857559	3857560	F 7	3851497	3851467	3851477
F 4	3851484	3851464	3851474	F 8	3851498	3851468	3851478
F 5	3851495	3851465	3851475	F 9	3851499	3851469	3851479

Type FH for DPS-B (helical/spiral splines)

DIM	Set	Front	Rear	DIM	Set	Front	Rear
FH 2	3885838	3885846	3885847	FH 6	3885842	3885854	3885855
FH 3	3885839	3885848	3885849	FH 7	3885843	3885857	3885859
FH 4	3885840	3885850	3885851	FH 8	3885844	3885860	3885861
FH 5	3885841	3885852	3885853	FH 9	3885845	3885862	3885863

FWD DRIVE

Type K – Stainless-steel Duoprop propellers

Specifically designed for the Volvo Penta Forward Drive. These propellers are made of a strong and durable stainless-steel to provide excellent acceleration and top speed. The patented bushing made of a naval brass reduces vibrations, stress on the drivetrain components and prevents corrosion by galvanically isolating the stainless-steel propeller from the aluminum drive casting.

DIM	Set	Front	Rear	DIM	Set	Front	Rear
K2	22417005	22414377	22414383	K5	22417008	22414380	22414386
K3	22417006	22414378	22414384	K6	22417009	22414381	22414387
K4	22417007	22414379	22414385	K7	22417010	22414382	22414388





DP280, 290, DP DRIVES

Type J – Aluminum Duoprop propellers

A completely modern aluminum propeller designed for our classic Duoprop drives. The patented blade geometry and large propeller diameter provides optimal efficiency as well as quiet and smooth operation. A special high-strength aluminum alloy and squeeze casting process makes the propellers stronger and more durable than traditional die-cast propellers. Four layers of paint ensures excellent corrosion protection performance.

Note! Always use type C stainless steel propellers in engines exceeding 240 hp or capable of speeds above 38 knots (45 mph). See next page.

DIM	Set 	Front 	Rear 
J 2	21924262	21924222	21924242
J 3	21924263	21924223	21924243
J 4	21924264	21924224	21924244
J 5	21924265	21924225	21924245
J 6	21924266	21924226	21924246
J 7	21924267	21924227	21924247
J 8	21924268	21924228	21924248
J 9	21924269	21924229	21924249
J 10	21924270	21924230	21924250







Upgrade from type A or type B propellers to type J propellers

To ensure the best performance for your boat, consult your Volvo Penta dealer for advice on the right propeller size for your drive and engine. **Note!** Do not mix Type A, B and J propellers. Always use propellers of the same type and size on the drive (or on both drives in twin installations).

Type A – Aluminum Duoprop propellers

Aluminium DP propeller for diesel engines up to 200 hp. The unique design, of the 3-blade propeller in the front and the 4-blade propeller behind, is the key to the outstanding grip in the water.







DIM	Set 	Front 	Rear 	DIM	Set 	Front 	Rear 
A 0	872270	872259	872264	A 6	**	854779	854789
A 1	854764	854774	854784	A 7	**	854780	854790
A 2	**	854775	854785	A 8	**	854781	854791
A 3	**	854776	854786	A 9	**	854782	854792
A 4	**	854777	854787	A 10	**	854783	854793
A 5	**	854778	854788				

** For complete kit use the J-series propellers.



Type B – Aluminum Duoprop propellers

Aluminium DP propeller for gasoline and diesel engines (diesel up to 230 hp). The two 3-blade propellers have very thin blade profiles, demanding the highest level of precision. For speeds above 35 knots we recommend the stainless Type C propeller.

DIM	Set 	Front 	Rear 	DIM	Set 	Front 	Rear 
B 1	**	854822	854830	B 5	**	854826	854834
B 2	**	854823	854831	B 6	**	854827	854835
B 3	**	854824	854832	B 7	**	854828	854836
B 4	**	854825	854833	B 8	**	854829	854837







** For complete kit use the J-series propellers.



DP280, 290, DP DRIVES

Type C – Stainless-steel Duoprop propellers

The Volvo Penta state-of-the-art stainless steel DP propeller has been specially designed to give maximum thrust where most needed. The high speed is achieved through thinner blades and powerful thrust. Greater torsional strength adds faster acceleration. The stainless steel material makes the propellers durable and highly resistant to cavitation, damage and corrosion. All these factors contribute to excellent handling and comfort.

DIM	  			DIM	  		
	Set	Front	Rear		Set	Front	Rear
C 2	3588222	3587864	3587870	C 5	3588225	3587867	3587873
C 3	3588223	3587865	3587871	C 6	3588226	3587868	3587874
C 4	3588224	3587866	3587872	C 7	3588227	3587869	3587875



DPR DRIVES

Type GR – Stainless-steel Duoprop propellers

The GR propeller is developed to handle the outstanding demand for thrust and strength placed by the DPR high speed drive developed for the D4 and D6 engines. Made in stainless steel.

DIM	  		
	Set	Front	Rear
GR7	3863492	3863501	3863502
GR8	3863493	3863503	3863504
GR9	3863494	3863505	3863506





GENUINE VOLVO PENTA PROPELLERS

Features, benefits and specifications

Volvo Penta

Duoprop propellers for Aquamatic Sterndrives

Two propellers. One superior thrust.

Launched in 1992, Volvo Penta proved the marine industry that two propeller designs could produce unparalleled thrust, strength and fuel economy along with their advantages – a completely new boating experience.

The design combination designed to form a unit part of the sterndrive provides stable efficient and predictable handling together with excellent reduced water resistance.

Two solid bronze propellers in designed shape and manufactured together to ensure set with a high torsion strength for the best possible performance – all in a compact setting for easy life at sea.

Stainless-steel ensures the most durable propeller material available and that efficiency through low friction and strength as well as excellent corrosion resistance.

Securely mounted into the engine. Features a precision-machined shaft with a stainless-steel collar for secure mounting.

Proven design of two propellers achieves maximum efficiency. The propellers have the same 100% pitch and are designed to work together to provide maximum performance and fuel economy.

Block-shifting allows easy shifting to the top or bottom gear, ensuring easy shifting from the sterndrive to the outboard motor.

Optimal bronze distribution ensures that the propellers are balanced for the best possible performance for the life of the sterndrive.

DPS Drives

Type F and F4 – Stainless-steel Duoprop propellers

The F and F4 drives are designed for maximum performance, strength and quality. Features include stainless-steel propellers for superior thrust, strength and fuel economy. The high strength stainless-steel propellers provide excellent performance in rough water, even in churning water, and are highly resistant to cavitation. The stainless-steel propellers are also highly resistant to corrosion.

Type F for D16, D18 & D20 outboard engines

DIM	Set	Front	Rear	DIM	Set	Front	Rear
F 1	3588222	3587864	3587870	F 2	3588225	3587867	3587873
F 3	3588223	3587865	3587871	F 4	3588226	3587868	3587874
F 5	3588224	3587866	3587872	F 6	3588227	3587869	3587875

Type F4 for D16, D18 & D20 outboard engines

DIM	Set	Front	Rear	DIM	Set	Front	Rear
F 7	3863492	3863501	3863502	F 8	3863493	3863503	3863504
F 9	3863494	3863505	3863506	F 10	3863495	3863507	3863508

Installation hardware, Type D, E, F, F4

Part	Part No.	Part	Part No.
Shaft	3588222	Shaft	3588225
Collar	3588223	Collar	3588226
Collar	3588224	Collar	3588227
Collar	3588225	Collar	3588228

Learn more about Volvo Penta propellers, their features, benefits and installation hardware - Download the Propeller Guide.



SINGLE PROPELLERS FOR AQUAMATIC

Volvo Penta launched the first single propeller sterndrive over half a century ago. A lot has changed since 1959. Though technology continues marching forward, one factor remains the same – real performance comes from a perfectly matched propeller and driveline.

SX DRIVES

3-blade aluminum propeller

With its wide and efficient blade design this propeller offers excellent acceleration and top speed. The state-of-the-art squeeze casting process together with special high-strength aluminum alloy makes it stronger and more durable than traditional die-cast propellers. Four layers of paint ensure excellent anti-corrosion performance. Shock-absorbing rubber bushing reduces vibrations and stress on the drivetrain.

Aluminium Ø x Pitch	Front	Rear
14,3 x 21	-	3817469
14,2 x 23	-	3817470
14,5 x 19	3817473	3817468
14,8 x 17	3817472	3817467
15 x 15	3817471	3817466
15,5 x 12	-	-
15,5 x 13	3855477	16 x 13 3840720
15,5 x 14	3855478	-



4-blade aluminum propeller

The four-blade propeller features the same strength and durability as the three-blade propeller. Four blades provide increased torque for heavy loads and maneuverability together with great stern lifting and mid-range performance. Four layers of paint ensure excellent anti-corrosion performance. Shock-absorbing rubber bushing reduces vibrations and stress on the drivetrain.

Aluminium Ø x Pitch	Front	Rear
14,75 x 15	3587519	3587517
14,5 x 17	3587521	3587520
14,25 x 19	3587523	3587522
14 x 21	3587525	3587524
14 x 23	-	3587526



3-blade stainless steel propeller

This performance provider enhances top speed, acceleration and durability versus a comparable aluminum propeller. The blade configuration and through-hub exhaust design are important factors for high efficiency and performance. Shock-absorbing rubber bushing reduces vibrations and stress on the drivetrain. This high-strength stainless steel propeller really push the limits and makes it a perfect choice for high-power engines and fast boats.

Stainless steel Ø x Pitch	Front	Rear
14,75 x 17	3860714	3862462
14,75 x 19	3860715	3860708
14,75 x 21	3860716	3860709
14,25 x 23	3860717	3860710



200, 250, 270, 275, 280, 285, 290, SP DRIVES

Aluminum propeller with long hub – High-speed series

The increased blade area of the high speed propeller makes it most suitable for use with high power engines and at high revs. In a fast boat this does not only mean increased speed, it also means that a heavily loaded boat will plane more quickly and enjoy better fuel economy. The high speed propeller's excellent reversing characteristics also mean faster and safer quayside manoeuvring.

Note! Always use long hub propeller for V6, V8, AQD40, AQAD31/40/41 engines.

Ø x Pitch	Ø x Pitch		Ø x Pitch	
	Front	Rear	Front	Rear
14 x 17	854977	854992	16 x 9	854985
14 x 19	854978	854993	16 x 13	854986
14 x 21	854979	854994	16 x 15	854987
14 x 23	854980	854995	16 x 17	854988
15 x 15	854981	854996	16 x 19	854989
15 x 17	854982	854997	16 x 21	854990
15 x 19	854983	854998	16 x 23	854991
15 x 21	854984	854999		



Aluminum propeller with short hub – High-speed and standard series

The High-speed propeller features more blade area than the standard propeller. In a fast boat this does not only mean increased speed, it also means that a heavily loaded boat will plane more quickly, enjoying better fuel economy and increased cruising speed. The increased blade area also provides faster and safer quayside maneuvering.

Note! Always use long hub propeller for V6, V8, AQD40, AQAD31/40/41 engines.

Ø x Pitch	Ø x Pitch		Ø x Pitch	
	Front	Rear	Front	Rear
14 x 13	813284 STD	813285 STD	15 x 11	813296 STD
14 x 15	814626 HS	814631 HS	15 x 13	813316 STD
14 x 17	814627 HS	814632 HS	15 x 15	814611 HS
14 x 19	814628 HS	814633 HS	15 x 17	814612 HS



100 DRIVES

Aluminum propeller for 100 drives with cylindrical shaft and locking pin

HS = High Speed propeller

Ø x Pitch	Ø x Pitch	
	Front	Rear
13 x 13	813224	813233
13 x 15	839186 HS	
14 x 11	813227	
14 x 11	804449*	
14 x 13	813229	
14 x 15	832992	

* For 100 drives with splines (13/16")



PROPELLERS FOR VOLVO PENTA IPS

When Volvo Penta launched the revolutionary IPS (Inboard Performance System) we set a completely new standard in efficiency, comfort and maneuverability. By turning the propellers around to a forward-facing position, the world of boating changed forever. These twin counterrotating propellers form an important part of the hydro-dynamically designed propulsion unit – pulling the boat through the water rather than pushing it.

IPS 1, IPS 10

Type T/TS – Nibral propellers

Specifically developed for IPS with D4 and D6 engines to give outstanding efficiency, onboard comfort and maneuverability.

DIM	Set	Front	Rear	DIM	Set	Front	Rear
T53	21368025	21368026	21368027	T5	23442955	24044385	24044435
T54	21368016	21368017	21368018	T6	23442956	24044386	24044436
T55	21258473	21258474	21258475	T7	23442957	24044387	24044437
T56	21368012	21368013	21368014	T8	23442958	24044388	24044438
T2	3861092	3861093	3861094	T9	23442959	24044389	3861115
T3	3861095	3861096	3861097	T10	23442960	3861117	24044440
T4	23442954	24044384	24044434				



IPS 15

Type N/NS – Nibral propellers

Specifically developed for IPS with D8 engines to give outstanding efficiency, onboard comfort and maneuverability.

DIM	Set	Front	Rear	DIM	Set	Front	Rear
NS4	21916044	21915974	21915994	N4	21808224	21808194	21808214
NS5	21916045	21915975	21915995	N5	21808225	21808195	21808215
N1	21808221	21808191	21808211	N6	21808226	21808196	21808216
N2	21808222	21808192	21808212	N7	21808227	21808197	21808217
N3	21808223	21808193	21808213				



IPS 2, IPS 20

Type P/PS – Nibral propellers

Specifically developed for IPS with D11 engines to give outstanding efficiency, onboard comfort and maneuverability.

DIM	Set	Front	Rear	DIM	Set	Front	Rear
PS4	23427144	23427154	23427184	P4	23427064	23427074	23427084
PS5	23427145	23427155	23427185	P5	23427065	23427075	23427085
P1	23427061	23427071	23427081	P6	3843968	23427076	23427086
P2	23427062	23427072	23427082	P7	23427067	23427077	23427087
P3	23427063	3843960	23427083	P8	3843974		



IPS 3, IPS 30

Type Q/QS – Nibral propellers

Specifically developed for IPS with D13 engines to give outstanding efficiency, onboard comfort and maneuverability.

DIM				DIM			
	Set	Front	Rear		Set	Front	Rear
QS4	21821364	21821254	21821264	Q4	21433624	21433604	21433614
QS5	21821365	21821255	21821265	Q5	21433625	21433605	21433615
Q1	21433621	21433601	21433611	Q6	21433626	21433606	21433616
Q2	21433622	21433602	21433612	Q7	21433627	21433607	21433617
Q3	21433623	21433603	21433613	Q8	21433628	21433608	21433618



Type QE – Nibral propellers

The QE series is developed for marine commercial vessels operating in polluted waters with a lot of debris. It has thicker blades compared to Q, adding strength but can slightly reduce the top speed.

DIM				DIM			
	Set	Front	Rear		Set	Front	Rear
QE1	22059721	22059611	22059631	QE3	22059723	22059613	22059633
QE2	22059722	22059612	22059632	QE4	22059724	22059614	22059634



Line Cutter

The line cutter is mounted to the rear propeller which creates a very efficient rotating cutting action. It is easy to install using the existing locking bolts and does not increase drag or fuel consumption.

Fits	Part No	Qty	Diameter	Material
IPS 1 [®] IPS 10 [®]	23062729	1	95 mm / 3.7"	316 Stainless steel
IPS 15 [®]	21913550	2	105 mm / 4.1"	316 Stainless steel
IPS 2 [®] IPS 20 [®]	21686494	1	120 mm / 4.7"	316 Stainless steel
IPS 3 [®] IPS 30 [®]	21686496	1	140 mm / 5.5"	316 Stainless steel



[®] Included as standard from serial number: IPS 1 = 3940018643, IPS 2 = 3950002140, IPS 3 = 3950001773.

[®] Included as standard from production start.

VOLVO PENTA FOLDING PROPELLERS - SAILING WITHOUT COMPROMISE

Volvo Penta folding propellers offer the best of both worlds – minimal drag while sailing combined with the high thrust of a fixed propeller while motoring – even in reverse. The unique and patented design always ensures quick and safe opening of the blades for excellent close-quarter maneuverability and minimal stopping distance.

Excellent durability and corrosion resistance thanks to specially developed nibral (nickel-bronze-aluminum) alloy.

High-skew blade design reduces pressure pulses to ensure smooth, low-noise operation with minimal vibrations.

Powerful thrust, even in reverse thanks to the highly efficient and patented blade geometry.



Minimizing drag and increasing speed

Volvo Penta folding propellers improve the performance of your boat minimizing drag and increasing speed – up to 1.5 knots under sail, compared with a fixed propeller. In addition, the sleek profile also reduces the risk of snagging ropes, nets and debris when sailing.

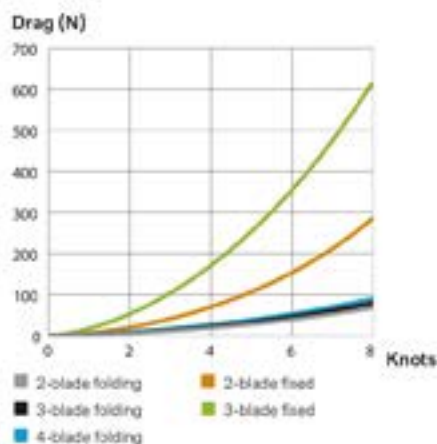

The test was carried out by SSPA Maritime Consulting. All propellers were mounted on a Saildrive propulsion system.

The graph shows the difference in propeller drag and how rapidly the drag increases with fixed propellers and higher speed. At 8 knots for example, a 3-blade fixed propeller produces more than six times the drag of a 3-blade folding propeller. This means a typical journey across the English Channel can be reduced by up to 4 hours thanks to lower drag.

Instant and powerful response – even in reverse

The patented design, with protruding blade tips ensures an instant opening action when the reverse gear is engaged. As soon as the propeller begins to rotate, mounting water pressure on the blade tips forces the blades to open. Centrifugal force then finalizes the opening action.

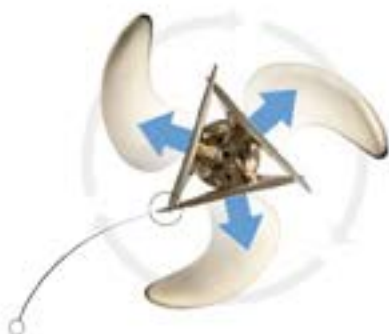

Rubber bushing and galvanic isolation

Hubs for saildrive propellers include a shock-absorbing rubber bushing to minimize stress on the drivetrain caused by gear changes. In addition, the bushing is designed to galvanically isolate the propeller from the saildrive – preventing galvanic corrosion caused by the propeller.

2-BLADE FOLDING PROPELLER FOR 5-40 HP





Designed for engines from 5 up to 40 hp. Available in multiple sizes and pitches for both S-drives and shafts. Made of extremely strong and durable nibral (nickel-bronze-aluminum) alloy.

- Powerful thrust even in reverse thanks to patented blade geometry
- Smooth, low-noise operation with minimal vibrations
- Safe opening with quick response in both forward and reverse
- Rubber bushing and galvanic isolation (hubs for S-drives)

Note! For a complete propeller, order one blade kit and one hub kit. Propeller size has to be calculated to match engine and gear ratio, please contact your Volvo Penta dealer.



Blade kits

Ø x Pitch	S-Drive & shaft		Shaft		Ø x Pitch	S-Drive & shaft		Shaft	
									
14 x 7	21629132	21629136	16 x 11	21629182	21629186				
14 x 8	21629140	21629144	17 x 11	21629190	21629194				
15 x 8	21629147	21629152	17 x 12	21629198	21629201				
15 x 10	21629158	21629167	18 x 12	21629205	21629211				
16 x 10	21629173	21629177	19 x 13	21629214	21629218				

Blade kit includes: Blades, hex key for locking screw (pos 11), propeller grease and installation instruction.

Hub kits

Hub kit for S-drives		Hub kit for shafts	
110S, 120S, MS25S, 130S, 150S	21630720	Pre-drilled hub*	21630725
Hub kit for metric standard shaft (1:10 taper)		Hub kit for SAE standard shaft (1:16 taper)	
25 mm shaft (key 6 mm)	21630721	1" shaft (key 5/16")	21630723
30 mm shaft (Key 8 mm)	21630722	1 1/4" shaft (key 5/16")	21630724

Hub kit includes: Zinc anodes, locking fluid and installation hardware listed in the table below. * Hub pre-drilled with 8 mm hole. Require final machining to the required shaft diameter and taper. Suitable for shafts up to 31,75 mm (1 1/4").

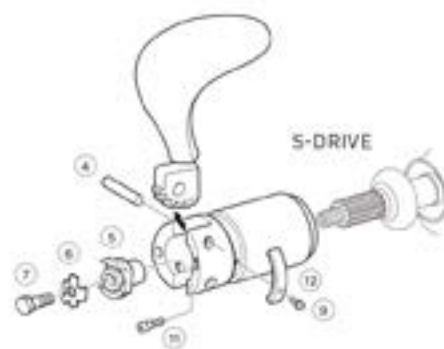
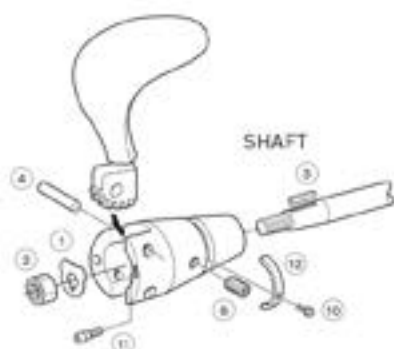

Installation hardware, 2-blade folding propeller

Pos	Part No	Qty	Description
1	873475	1	Tab washer, M16
1	873488	1	Tab washer, M20
2	873473	1	Nut, prop shaft, M16
2	873486	1	Nut, prop shaft, M20
3	873474	1	Key, prop shaft, Ø25mm
3	873487	1	Key, prop shaft, Ø30mm
4	21626924	2	Shaft 1, 2)
5	3584466	1	Propeller nut 1)

Pos	Part No	Qty	Description
6	3851994	1	Lock washer 1)
7	946730	1	Hexagon screw 1)
8	3581246	2	Screw 2)
9	963677	3	Hex. socket screw 1)
10	963675	2	Hex. socket screw 2)
11	3595221	2	Lock screw 1, 2)
12		3	Zinc anode 1, 2, 3)
	23284156	1	Locking fluid (10 ml) 1, 2)

1) Included in hub kit for S-drive. 2) Included in hub kit for shaft. 3) For part number, see page 73.

3-BLADE FOLDING PROPELLER FOR 20-60 HP

Designed for engines from 20 up to 60 hp. Available in multiple sizes and pitches for both S-drives and shafts. Made of extremely strong and durable nibral (nickel-bronze-aluminum) alloy.

- Powerful thrust even in reverse thanks to patented blade geometry
- Smooth, low-noise operation with minimal vibrations
- Safe opening with quick response in both forward and reverse
- Rubber bushing and galvanic isolation (hubs for S-drives)

Note! For a complete propeller, order one blade kit and one hub kit. Propeller size has to be calculated to match engine and gear ratio, please contact your Volvo Penta dealer.



Blade kits

	S-Drive & shaft	Shaft		S-Drive & shaft	Shaft
Ø x Pitch			Ø x Pitch		
14 x 7	—	3583409	17 x 12	3583388	3583417
14 x 8	—	3583410	18 x 12	3583389	3583418
14 x 9	3583382	3583411	18 x 13	3583390	3583419
15 x 9	3583383	3583412	18 x 14	3583391	3583420
15 x 10	3583384	3583413	18 x 15	3583392	3583421
16 x 10	3583385	3583414	18 x 16	3584031	3583422
16 x 11	3583386	3583415	19 x 16	3583393	3583423
17 x 11	3583387	3583416			

Blade kit includes: Blades, hex key for locking screw (pos 10), propeller grease and installation instruction.

Hub kits

Hub kit for S-drives		Hub kit for shafts	
1105, 1205, MS255, 1305, 1505	3858955	Pre-drilled hub*	3583428
Hub kit for metric standard shaft (1:10 taper)		Hub kit for SAE standard shaft (1:16 taper)	
25 mm shaft (key 6 mm)	3583424	1" shaft (key 1/4")	3583426
30 mm shaft (Key 8 mm)	3583425	1 1/4" shaft (key 5/16")	3583427

Hub kit includes: Zinc anodes, locking fluid and installation hardware listed in the table below. * Hub pre-drilled with 8 mm hole. Require final machining to the required shaft diameter and taper. Suitable for shafts up to 31,75 mm (1 1/8").

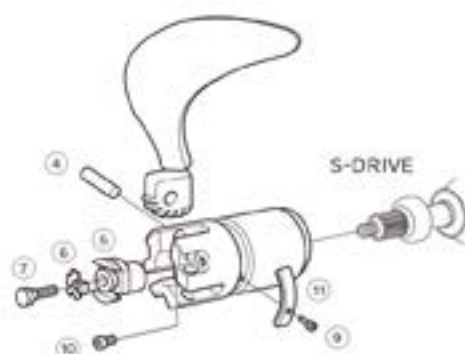
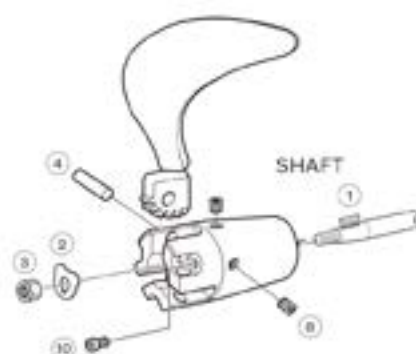

Installation hardware, 3-blade folding propeller

Pos	Part No	Qty	Description
1	873474	1	Key, prop shaft, Ø25mm
1	873487	1	Key, prop shaft, Ø30mm
2	873475	1	Tab washer, M16
2	873488	1	Tab washer, M20
3	873473	1	Nut, prop shaft, M16
3	873486	1	Nut, prop shaft, M20
4	3581243	3	Shaft 1, 2)
5	3584466	1	Propeller nut 1)

Pos	Part No	Qty	Description
6	3851994	1	Lock washer 1)
7	946730	1	Hexagon screw 1)
8	3581246	2	Screw 2)
9	963677	3	Hex. socket screw 1, 2)
10	963695	3	Hex. socket screw 1)
11		3	Zinc anode 1, 3)
	23284156	1	Locking fluid (10 ml) 1, 2)

1) Included in hub kit for S-drive. 2) Included in hub kit for shaft. 3) For part number, see page 73.

4-BLADE FOLDING PROPELLER FOR 55-120 HP

Designed for engines from 55 up to 120 hp. Available in multiple sizes and pitches for both S-drives and shafts. Made of extremely strong and durable nibral (nickel-bronze-aluminum) alloy.

- Powerful thrust even in reverse thanks to patented blade geometry
- Smooth, low-noise operation with minimal vibrations
- Safe opening with quick response in both forward and reverse
- Rubber bushing and galvanic isolation (hubs for S-drives)

Note! For a complete propeller, order one blade kit and one hub kit. Propeller size has to be calculated to match engine and gear ratio, please contact your Volvo Penta dealer.



Blade kits

S-Drive & shaft		Shaft		S-Drive & shaft		Shaft	
Ø x Pitch			Ø x Pitch				
20 x 14	3583917	3583918	22 x 18	3583923	3583924		
21 x 15	3583919	3583920	22 x 20	3583925	3583926		
22 x 16	3583921	3583922					

Blade kit includes: (blades), hex key for locking screw (pos 10), propeller grease and installation instruction.

Hub kits

Hub kit for S-drives		Hub kit for metric standard shaft (1:10 taper)	
110S, 120S, MS25S, 130S, 150S	3583927	25 mm shaft (key 6 mm)	3583928
Hub kit for SAE standard shaft (1:16 taper)		30 mm shaft (Key 8 mm)	3583929
1 1/4" shaft (key 5/16")	3583931	35 mm shaft (Key 10 mm)	3583930
1 1/2" shaft (key 3/8")	3583932	40 mm shaft (Key 12 mm)	3584137

Hub kit includes: Zinc anodes, locking fluid and installation hardware listed in the table below. * Hub pre-drilled with 8 mm hole. Require final machining to the required shaft diameter and taper. Suitable for shafts up to 31,75 mm (1 1/4").

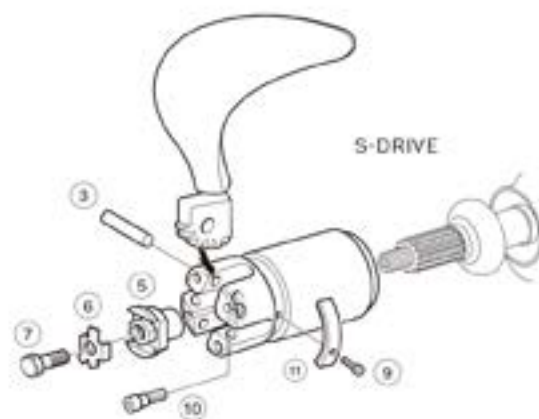
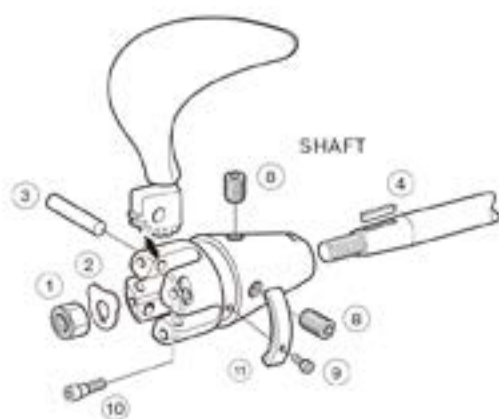

Installation hardware, 4-blade folding propeller

Pos	Part No	Qty	Description
1	873473	1	Nut, prop shaft, M16
1	873486	1	Nut, prop shaft, M20
1	3587422	1	Nut, prop shaft, M24 4)
2	873475	1	Tab washer, M16
2	873488	1	Tab washer, M20
2	873506	1	Tab washer, M24
3	3583951	4	Shaft 1, 2)
4	873474	1	Key, prop shaft, Ø25mm
4	873487	1	Key, prop shaft, Ø30mm
4	873496	1	Key, prop shaft, Ø35mm



Pos	Part No	Qty	Description
4	873505	1	Key, prop shaft, Ø40mm
5	3584466	1	Propeller nut 1)
6	3851994	1	Lock washer 1)
7	946730	1	Hexagon screw 1)
8	3581246	2	Screw 2)
9	963677	3	Hex. socket screw M5x16 1, 2)
10	963695	4	Hex. socket screw M6x14 1, 2)
11		3	Zinc anode 1, 2, 3)
	23284156	1	Locking fluid (10 ml) 1, 2)

1) Included in hub kit for S-drive, 2) Included in hub kit for shaft, 3) For part number, see page 73, 4) Included in hub kits 3583930 & 3584137.

FIXED PROPELLERS FOR SAILDRIVE

Our fixed propellers are exclusively designed for Volvo Penta saildrives. Manufactured using high-quality, durable aluminum alloy and with a rubber bushing in the hub, you get efficient and comfortable motoring, while securing the service life of your saildrive.

2-Blade (S-drives 110S, 120S, 130S and 150S)



S-Drive Ø x Pitch		S-Drive Ø x Pitch	
14 x 7	23478911	16 x 13	23478917
14 x 8	23478912	17 x 14	23478918
14 x 9	23478913	17 x 16	21351265
14 x 11	23478914	17 x 17	23478920
15 x 11	23478915	19 x 17	21351284
16 x 11	23478916		



2-Blade (S-drive 100S)

S-Drive	Ø x Pitch	
MD6A	14 x 8	839514
MB10A, MD11C	16 x 11	839191

3-Blade (S-drives 110S, 120S, 130S and 150S)

S-Drive Ø x Pitch		S-Drive Ø x Pitch	
14 x 9	23478961	17 x 12	23478967
14 x 11	23478962	17 x 13	23478968
14 x 12	23478963	17 x 14	23478969
15 x 12	21381264	17 x 15	23478970
15 x 13	23478965	17 x 16	23478971
16 x 11	23478966	18 x 16	23478972



Installation hardware, fixed propellers for S-drives 110S, 120S, MS25S, 130S, 150S

Part No	Qty	Description
23748222	1	Propeller cone kit
23748333	1	Screw *
23680979	1	Lock washer*

* Included in propeller cone kit

Choose the right anode

Below are our general recommendations on how to choose the anode for the type of water where the boat is used:

Saltwater	–	Zinc or Aluminum
Brackish water	–	Aluminum*
Freshwater	–	Magnesium

* If aluminum anode is not available for your product, select zinc anode instead.

ANODES

Anodes are to be sacrificed in order to protect the drive unit and propeller against galvanic corrosion. Volvo Penta anodes are tested and specially produced for Volvo Penta drives and propellers.

Aquamatic sterndrive – Single prop drives

Lower gear	Zinc	Aluminum	Magnesium
100 drive	875810	–	–
200 – 290, SP	875815	–	876137
Spray plate	Zinc	Aluminum	Magnesium
SX	3855411	3863193	3855412
SX-A	3888814	23164609	3888815
Transom shield	Zinc	Aluminum	Magnesium
200-280	832598	–	873179
290, SP	852835	–	873178
SX	3854130	3586461	3855610
SX-A	3000017	23164611	3000010

Aquamatic sterndrive – Duoprop drives

Lower gear	Zinc	Aluminum	Magnesium
280, 290, DP	875821	–	876138
Spray plate	Zinc	Aluminum	Magnesium
DP-S, DP-SM	3855411	3863193	3855412
DPS-A, DPS-B, FWD	3888814	23164609	3888815
DPH	3588746	3588748	3588750
DPR	3588875	3588876	3588877
DPX	876638	–	–
DPI	–	23520859	23520860
Transom shield	Zinc	Aluminum	Magnesium
280	832598	–	873179
290, DP	852835	–	873178
DP-S, DP-SM	3854130	3586461	3855610
DPS-A, DPS-B, FWD	3888817	23164611	3888818
DPH, DPR	3588745	3588770	3588768
DPX	872139	–	–
DPI	–	3588770	3588768

S-Drive

Lower gear	Zinc	Aluminum	Magnesium
110S	875812	–	876603
120S, MS255	876286	–	876604
130S, 150S (2 piece anode)	22651246	–	22651247

Folding propeller

S-drive	Zinc	Aluminum	Magnesium
2-blade propeller	3858399	–	3858400
3-blade propeller	3858399	–	3858400
4-blade propeller	3584442	–	3584443
Shaft	Zinc	Aluminum	Magnesium
2-blade propeller	3888491	–	3888493
3-blade propeller (Use anode for shaft mounting)	–	–	–
4-blade propeller	3584442	–	3584443

Volvo Penta IPS

	Part number*
Lower gear anode	3593981
Transom anode IPS 1	23172849
Transom anode IPS 15, IPS 2, IPS 3, IPS 30	23418772

* The anode system for Volvo Penta IPS is designed to provide protection in salt-, brackish- and freshwater.

Back-up anodes for Active Corrosion Protection can be found in the next chapter.



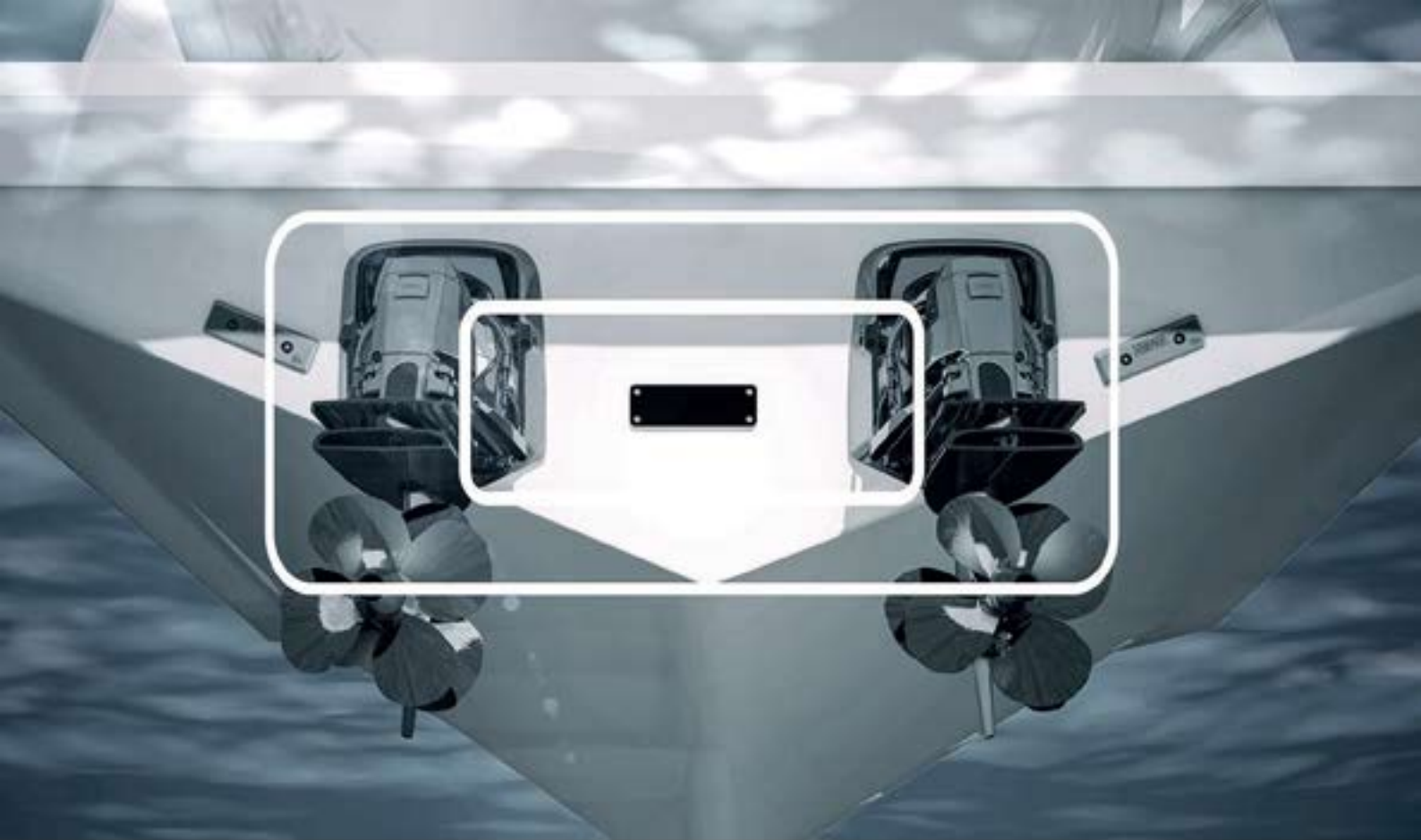

ACTIVE CORROSION PROTECTION

Volvo Penta Active Corrosion Protection (ACP) for Aquamatic sterndrives and Volvo Penta IPS provides easier ownership and enhanced corrosion protection for your drive compared to using conventional sacrificial anodes. The system continuously

measures the electrical potential of the drive and automatically adjusts the electrical output for ideal protection - in both salt and brackish water.

Fully integrated for easy of use

The ACP system is fully automated and integrated with the Electronic Vessel Control system (EVC). The protection status is continuously monitored and presented in the engine displays at the helm. No extra displays are needed and no need to worry about sacrificial anodes; the ACP system provides additional peace of mind.

Higher protection capacity

Thanks to the impressed current cathodic protection (ICCP) technology used by the ACP system, the capacity to protect the drive is much higher than with conventional zinc or aluminum sacrificial anodes. The system replaces the sacrificial anodes on the drive for Aquamatic sterndrives and the standard transom mounted sacrificial anodes for Volvo Penta IPS installations.

Requirements

- Volvo Penta IPS or Aquamatic sterndrives: DPI, DPH, DPS, SX, OX, FWD or DPR
- Electronic Vessel Control (EVC) generation C2 and later
- EVC displays: 2,5", 4", 7" or Glass Cockpit
- Fiberglass hull



A complete package

The ACP system consists of a control unit, a transom unit and a backup zinc anode (two anodes for twin Aquamatic stern drives).

The ACP system is delivered with all components needed including installation instructions. Note: Extra bonding cable needed for IPS in triple and quad installations.

ACP kits – EVC C2 to EVC E

Part no	Single	Twin	Triple ¹⁾	Quad ²⁾
Aq ³⁾	23025662	23254031	—	—
IPS1	—	24050632	24050632	24050632
IPS15	—	24050632	24050632	—
IPS2/20	—	24050632	— ³⁾	— ³⁾
IPS3/30	—	24050632	— ³⁾	— ³⁾

ACP kits – EVC2

Part no	Single	Twin	Triple ¹⁾	Quad ²⁾
Aq ³⁾	23481461	23481462	—	—
IPS10	—	23943063	23943063	—

Part no	Bonding cable
21200402	Bonding cable, IPS triple and quad ³⁾

1) DPI, DPH, DPS, SX, CX, FWQ, DPR

2) Extra bonding cable required (between IPS units). Order one for triple installations and two for quad installations.

3) Kit will be available in quarter two 2021.

Replacement back-up anodes

Part no	Transom mounted anode
23291530	Aquamatic stern drive
40005206	IPS



Part no	Integrated anode ⁴⁾
21174476	IPS



4) Back-up anode for previous model of ACP system for IPS (anode integrated with transom unit).

ACP-S for stern drives and outboards

This is a stand alone system designed for stern drives and outboards in general. It has a lower capacity than the EVC integrated systems and complements the standard sacrificial anodes rather than replacing those. It is not recommended for DPH/DPI drives or larger outboards.

The ACP-S is designed to protect one stern drive or outboard, and an additional kit is required for installation on a twin engine boat.

Requirements

- Fiberglass hulls used in salt water.
- 12 V Electrical system

Part no	Drive
3587839	Stern drives (not DPH/DPI) and outboards
3887090	SX-A, DPS-A, DPS-B



HOW DOES IT WORK?

The ACP system uses impressed current cathodic protection (ICCP) to protect the drive. It constantly monitors the electrode potential of the drive and carefully adjusts the current output via the transom unit to keep the drive within safe potential levels. Compared to conventional sacrificial anodes, the main benefits of an active system are better control of the level of protection, visibility of the protection status at the helm and, of course, that no anodes are consumed while the system is active.

Under most conditions, the ACP system typically uses less than 50 mA to provide protection for a single Aquamatic stern drive installation or less than 350 mA for a triple IPS1/10 installation with unpainted drives (with painted drives*, the consumption can be reduced to less than 50 mA). However, it has a current capacity of 3A to maintain corrosion protection of the drives under more demanding conditions.

It is recommended to have shore power connected while berthed. When shore power is not available and the battery state of charge drops below 75%, the system will enter a monitor only mode where the protection status can be viewed at the helm, but protection will be provided by the back-up sacrificial anodes. Below 50% battery state of charge, the system will be inactive, and protection will be provided by the back-up anodes.

* Always follow Volvo Penta's instructions for painting IPS drives and the legislation that regulates the use of antifouling paints where the boat is used.



The system comes complete with wiring and detailed installation instructions. Standard tools, a drill and suitable underwater sealant are all that is required for most installations.

EXCHANGE COMPONENTS

Genuine performance, lower cost

The Volvo Penta Exchange system gives you access to a comprehensive range of factory remanufactured components – from injectors and turbos to longblocks and IPS drive units – offering a cost-effective alternative to repair and overhaul that brings new life and power to your Volvo Penta product.

The benefits of Volvo Penta Exchange components

- Completely remanufactured to new condition by Volvo Penta
- Updated to the latest technical specifications

- Same quality, reliability and performance as new Genuine Volvo Penta Parts
- Cost-effective alternative to repair and overhaul
- Quick exchange, less downtime
- Environmental benefits through recycling
- Covered by the Volvo Penta 12-month standard warranty, or 24 months when fitted by an authorized Volvo Penta dealer

Download our Exchange catalogue at volvopenta.com or contact your local Volvo Penta dealer for more information.



Learn more about the Volvo Penta remanufacturing process – Watch the video.



Based on a recycle program

Volvo Penta Exchange System is based on a recycle program where you trade in a corresponding worn component in return for a new Exchange component. The program allows you to return the worn component once the new component is installed and the engine is running again.

When buying an Exchange component, a fee will be added on the invoice. The fee is refunded as soon as the worn component is returned.

MAINTENANCE



TAKE CARE OF YOUR EQUIPMENT

Regular maintenance and the use of Genuine Volvo Penta Parts will allow you to get the most out of your engine and your time on the water. This section gives you an overview of maintenance products that will help keep your engine running smoothly and at peak performance.

Your Volvo Penta dealer is always ready to provide expertise and service so you can focus on what's most important — enjoying your time on the water.



VOLVO PENTA OILS

We and the Volvo Group invest significant resources in developing high-performance oils. And the reason is simple. Oil quality plays a vital role to get the most out of the engine and keep the cost of ownership down. As engines continue to evolve, with increased efficiency and more precise technology, it placing greater demands on oil performance than ever before.

Genuine Volvo Penta oils are extensively tested and quality assured by Volvo Penta. They are formulated to meet the specific requirements of Volvo Penta engines and include powerful additive technology which are individually selected to optimize performance, reduce fuel consumption and extend the life of the engine.



Engine oil VDS-3

VDS-3 covers even more stringent requirements on piston cleanliness and bore polish compared to VDS-2, ensuring the durability and reliability of the engine. The high quality of VDS-3 oils allows in certain cases an increase in drain intervals. Fits both diesel and gas engines (check operators manual).

Viscosity: SAE 15W-40

Grade: VDS-3

Part no	Pack	Quantity
23909453	Plastic bottle	1 Litre
23909454	Plastic container	5 Litre
23909456	Plastic container	20 Litre



Engine oil VDS-4.5

High-performance heavy-duty engine oil providing outstanding protection and fuel economy. VDS-4.5 delivers improved engine cleanliness and protection against piston deposits through the use of high-quality base oils and additive components. VDS-4.5 15W-40 is fully backward compatible with all older Volvo Penta diesel engines. It is also recommended for certain gasoline engines, please refer to the operators manual.

Viscosity: SAE 15W-40

Grade: VDS-4.5

Part no	Pack	Quantity
23909459	Plastic bottle	1 Litre
23909460	Plastic container	5 Litre
23909461	Plastic container	20 Litre



Synthetic gasoline engine oil

A fully synthetic oil specially developed for high performance gasoline engines. Its wide temperature range capability maximizes engine life. The additive system is designed to provide protection against wear and minimize deposit and sludge build-up. Particularly suitable for all engines equipped with catalyst but is also applicable to non-catalyst engines produced in model year 2008 and later.

Viscosity: SAE 5W-40

Grade: ACEA C3, API SN

Part no	Pack	Quantity
23211287	Plastic bottle	1 Litre
23211288	Plastic container	5 Litre
23211290	Plastic container	20 Litre



Volvo Penta synthetic transmission oils are specifically designed for marine applications – offering significant advantages over conventional transmission oils.



Marine synthetic transmission oils

High-performance fully synthetic transmission oils, specifically designed to ensure excellent load-carrying capability over wide operating temperatures. Provides optimal shift performance and maximum protection against wear and corrosion. Advanced marine additive technology includes unique capabilities to minimize damage due to water contamination.

All this ensures significant advantages over conventional transmission oils and contributes to smooth operation and long-term health for the drive.

IPS and Aquamatic synthetic transmission oil 75W-90

Part no	Pack	Quantity	SAE
22479650	Plastic bottle	1 Litre	75W-90
22479648	Plastic container	5 Litre	75W-90
22479647	Plastic container	20 Litre	75W-90

For SX, SP-A2, SP-C (except ratio 2.15:1), DPS, FWD, DPL, DPH (except ratio 1.59:1), DPR, DPX, XDR, DP-A2 to DP-E, all IPS drives, S-drive 120S-E, reverse gear M52A1-E, MS4, MS5.

Synthetic transmission oil 75W-140

Part no	Pack	Quantity	SAE
22574246	Plastic container	5 Litre	75W-140

For DPH ratio 1.59:1 (DS-400) and DPQ drives (KAD300).



Transmission oil 80W-90

Lubrication properties protect drive and transmission even under heavy load. Also provides excellent corrosion protection.

Grade: API GL-5

Part no	Pack	Quantity	SAE
3809445	Plastic container	5 Litre	80W-90

For AQ100, 280DR, 290DR, DP-A1/A1 (except drives manufactured before 1986, for 30 or 40 series engine, and has previously used engine oil in the drive, continue to use engine oil).



Synthetic compressor oil

Specially tested in Volvo Penta compressors. Fully synthetic oil that withstands both high and low temperatures. Protects the compressor against corrosion.

Viscosity: ISO VG 68

Part no	Pack	Quantity
85108974	Plastic bottle	250 ml



Hydraulic Oil

For hydraulic steering system. Protects against wear at high and low temperatures. Also provides excellent corrosion protection. Particularly suitable for marine use. Does not affect seal materials.

Viscosity: ISO VG 15

Part no	Pack	Quantity
22618337	Plastic bottle	1 Litre



Automatic Transmission Fluid (ATF)

For power steering, power trim system and HS reverse gears. Protects against wear, even at high temperatures. Also provides a very good corrosion protection.

Note! Must not be used where API-GL5 is recommended.

ATF-oil, type Dexron III

Part no	Pack	Quantity
23909464	Plastic bottle	1 Litre
23909465	Plastic container	5 Litre



BETTER CONTROL

With Volvo Penta oil analysis you get a comprehensive health check of the engine's and transmission's condition.

The benefits of Volvo Penta oil analysis

- High-quality analysis done by accredited laboratories using specified limits values defined by Volvo Penta
- Comprehensive diagnosis of the engine's and transmission's condition
- Makes trends visible and provides early warnings for abnormal wear
- Increased control over engine status – providing additional peace of mind
- Helps to plan preventive maintenance

Volvo Penta oil analysis is available in most markets – please contact your local Volvo Penta Dealer for further information.



Electric oil drain pump

An electric oil drain pump makes oil changes considerably easier. The pump is self priming and permanently installed, thus eliminating the inconvenience of manually draining the oil sump. The pump is supplied with electrical cable with battery connectors, 3 meters rubber hose with 12 mm internal diameter and hose clamps.

Note! Not intended for mounting in gasoline engine rooms.

Part no	Voltage
843114	12 V
843410	24 V



Coolant VCS yellow

A high performance coolant (OAT) specially formulated for newer generations of Volvo Penta engines.

The benefits of Volvo Penta Coolant VCS:

- Prevents freezing and overheating.
- Maximum protection against corrosion, cavitation and build-up.
- Prevent internal engine component degradation, optimizing engine life.
- Four years change interval.

Part no	Colour	Type	Quantity
22567314	Yellow	Ready mixed	5 L (to -25°C)
22567335	Yellow	Ready mixed	20 L (to -25°C)
22567286	Yellow	Concentrated	1 L
22567295	Yellow	Concentrated	5 L
22567305	Yellow	Concentrated	20 L

Coolant green

A high performance coolant specially formulated for older generations of Volvo Penta engines.

The benefits of Volvo Penta Coolant:

- Prevents freezing and overheating.
- Maximum protection against corrosion, cavitation and build-up.
- Prevent internal engine component degradation, optimizing engine life.
- Two years change interval.

Part no	Colour	Type	Quantity
22567233	Green	Ready mixed	5 L (to -25°C)
22567259	Green	Ready mixed	20 L (to -25°C)
22567185	Green	Concentrated	1 L
22567206	Green	Concentrated	5 L
22567215	Green	Concentrated	20 L

Note! Do not mix Volvo Penta coolant VCS (yellow) and Volvo Penta coolant (green). They are formulated for the specific requirements of different engine generations and contain unique additives that are not compatible. Always use the same Volvo Penta coolant type that initially was delivered with the engine. Refer to the operators manual.



Mixing data for concentrated coolants

Concentrated coolant should be mixed with pure distilled, deionized water. Mix the liquids properly in a clean vessel before filling the cooling system. Note! Do not use tap water, it contains minerals that will form deposits inside the cooling system.

Recommended mixture	Anti-freeze protection
40% concentrated coolant	-25°C
50% concentrated coolant	-35°C
60% concentrated coolant	-46°C

Cleaning agent for Volvo Penta coolant VCS

High engine temperature can be caused by build-up of deposits in the cooling system which occur, usually, after long running time or the use of mineral rich water. When this occurs the cooling system must be cleaned with the help of a cleaning agent. The cleaner is a citric acid based solvent with the addition of a neutraliser. For yellow VCS coolant only.

Part no	Pack	Quantity
21487920	Plastic container	500 + 200 g



Grease it up. The propeller shaft should be cleaned and re-greased at least once a year, as well as when changing the propeller. Regular greasing will prevent the propeller from sticking to the Propeller shaft. Refer to the operators manual for recommended intervals.



Water resistant grease

Special grease for marine environments – especially suitable for salt water applications. Lubricates, seals and protects against corrosion. Withstands long-term high loading without any deterioration in protective properties. The grease is solid and water-resistant, for use in rubber packing boxes, greasing propeller shafts, folding propellers and all other propeller components.

Viscosity: NLGI 2

Part no	Pack	Quantity
828250	Tube	25 g
22618330	Plastic cartridge for grease gun	400 g

Impeller lubricant (Glycerine)

Rubber lubricant for impellers, oil-sensitive O-rings or rubber components.

Part no	Volume	Quality
3862178	7 g	Glycerine

Low-temperature grease

A special grease recommended for low loads and low temperatures (-50°C to +100°C). This grease is especially suitable for use on controls, hinges, lock parts and for greasing electric contacts, switches, etc. Not for EVC components.

Viscosity: NLGI 1

Part no	Pack	Quantity
1161417	Tube	30 g



Grease for traditional stuffing boxes

This grease is used for traditional propeller shaft stuffing boxes fitted with a greasing cup.

Viscosity: NLGI 3

Part no	Pack	Quantity
3809449	Plastic container	500 g



Silicone – Black sealing compound

A single component black silicon adhesive that cures at room temperature. Suitable for both gluing and sealing operations where a strong elastic seam capable of withstanding temperatures from -65°C to $+200^{\circ}\text{C}$ is required. Excellent adhesion to metal, rubber, glass and most plastics. The silicon adhesive is resistant to oils, greases, solvents, etc.

Part no	Pack	Quantity
1161277	Plastic tube	20 g
1161231	Plastic cartridge for grease gun	310 ml



Gasket cement

A viscous and slow drying cement intended primarily for gaskets and similar. Dries to a pliable film.

Part no	Pack	Quantity
1161099	Plastic container	125 ml



Master gasket – Liquid sealing agent

Replaces conventional paper gaskets and provides an immediate "custom made" gasket. Resistant to petrol, oil, anti-freeze, transmission oils and solvents. Operating temperature range: -50°C to $+150^{\circ}\text{C}$.

Part no	Pack	Quantity
22618325	Syringe applicator	25 ml



Sealant

A graphite based black sealant and rust-proofing agent for pipe joints, flanges, threaded connections on, for example, the exhaust system. Will not damage gasket materials even at high temperatures.

Part no	Pack	Quantity
1161929	Metal tin	1 kg



Locking fluid

Prevents screws and nuts from loosening due to shock and vibration. Allows disassembly with normal hand tools. Medium strength (blue). Also prevents corrosion and leakage.

Part no	Pack	Quantity
23284156	Bottle	10 ml



Rapid rust loosener

A multi purpose spray with excellent penetration and contact properties. It loosens rust seized metal parts connections and other mechanisms without destruction. It removes moisture in electric contacts, protects from corrosion and oxidation. It eliminates squeaking and reduces friction.

Part no	Pack	Quantity
1161928	Spray can	400 ml



Paints

Volvo Penta paints are the best protection against rust and corrosion for engines, drives and transmissions. The appearance and second hand value of the engine is enhanced when all painting operations are carried out using Volvo Penta paints.

Touch-up paint - engine

Part no	Colour	Pack	Quantity, Litres
22618341	Green, gloss	Tin	1,0
22618346	Red	Tin	1,0
22618344	Green, matt	Tin	1,0
22618302	White	Tin	1,0
1141566	Green, matt	Spray can	0,4
827501	Red	Spray can	0,4
3851221	Dark grey	Spray can	0,4



7-14. Touch-up paint - drive

Part no	Colour	Pack	Quantity, Litres	Image
1141567	Blue-grey	Spray can	0,4	7
1141575	Grey	Spray can	0,4	8
1141560	White	Spray can	0,4	9
1141568	Black, matt	Spray can	0,4	10
3851219	Silver, SX, DPS, FWD, IPS 1*	Spray can	0,4	11
827502	Clear varnish	Spray can	0,4	12
889968	Silver + clear varnish, DPG, DPH, DPR, S-drives, IPS**	Spray can, 2 pcs	0,4 + 0,4	13
3851220	Grey + clear varnish, DPX	Spray can, 2 pcs	0,4 + 0,4	14

* IPS 1 generation A, B, C (up to SN 3194009615) ** IPS 15, 2, 3, 30 and IPS 1 generation D and later (from SN 3194009616)

15. Primer

Part no	Colour	Pack	Quantity, Litres	Image
1141562	Blue-grey	Spray can	0,4	15



Bilge Oil Boom

The Bilge Oil Boom is ideal for keeping your bilge safe and clean. Simply drop or anchor (with attached rope) in the bilge and the Bilge Oil Boom will efficiently absorb waste oil, fuel and hydraulic fluid. Does not absorb water and will stay afloat even when soaked with oil.

Features:

- Super absorbent and hydrophobic, does not absorb water.
- Absorbs all kinds of petroleum spills.
- Absorbs up to 4,5 l.
- Boom is 380 x 130mm.
- 100% polypropylene absorbent surrounded by sounbond, polypropylene sock and nylon netting.

Part no
21699860



Oil & Water Sorbent Pads

The Oil & Water Sorbent Pads can be used for all engine and drive-related spills and leaks. Absorbs petroleum products, cooling liquid, water etc. You can even use it to wipe off the bilge after the work is done.

Features:

- Absorbs up to 0.7 l per pad.
- 400 x 500 x 4.7 mm
- Sold in a roll of 4 pads.
- Made from recycled polypropylene.

Part no
21699859

MAINTENANCE PARTS

Genuine Volvo Penta Parts are designed and manufactured to ensure original fit, safety and performance – making them the best choice for your Volvo Penta product.

This section gives you an overview of the most common parts that need to be replaced regularly to make sure your engine and drive continue to run smoothly and at peak performance.

Always refer to the operator's manual for the recommended maintenance and service intervals for your engine and drive.



Volvo Penta Maintenance Kits include the basic parts for regular maintenance. All kits contain exclusively Genuine Volvo Penta Parts and are pre-packed for easy ordering.



Maintenance kits for diesel engines

Contains oil filter, fuel filter and impeller with necessary gaskets. Kits for D4 and D6 engines also include air filter and by-pass oil filter. For D4/D6 A-F (-2019) the crankcase ventilation filter is also included.



Maintenance kits for Aquamatic Sterndrives

Contains zinc anodes, drive joint bellows and other required parts for regular maintenance.

Part no	Drive
877116	290, 290A, SP-A, SP-A1, SP-A2
877119	290DP, DP-A, DP-A1, DP-B, DP-B1
877120	SX, DP-S, DP-SM
877122	DP-C, DP-D, DP-E
23307656	DPG
23307655	DPH, DPR

Part no	Engine
877194	2001, 2002, 2003
21189380	MD2010C, MD2020C, MD2030A, MD2030B, MD2030C, MD2040A, MD2040B, MD2040C
877201	D30, D31, KAD32
877202	D40, D41
877203	KAD/KAMD 42, 43, 44, 300
21189380	D1-13, D1-20
21189422	D1-30, 2-40
21189426	D2-50, D2-55, D2-60, D2-75
21105842	D3 A-C (-MY2009)
21759184	D3 D-H (MY2010-)
D4/D6 A-F (-MY2019)	
21704968	D4 A-F all: Inboard engines, D4 A-D with AQ/IPS drives
22383875	D4 E-F with AQ/IPS drives SN 2004033317-
21704967	D6 A-F all: Inboard engines, D6 A-D with AQ/IPS drives
22383876	D6 E-F with AQ/IPS drives SN 2006040970-
D4/D6 G (MY2020-)	
23746227	D4 G
23746230	D6 G

MD1, MD2

22057107	Oil filter
23686345	Fuel filter, insert
829913	Fuel filter, spin-on
803729	Impeller, early models MD1/MD2 ¹⁾
3586494	Impeller kit, MD1/MD2 ²⁾ , MD1B/MD2B

1) Through hole pin drive 2) Slotted shaft pin drive

MD5, MD11

22057107	Oil filter
23686345	Fuel filter, insert
829913	Fuel filter, spin-on
21951342	Impeller kit (cover plate with 4 screws)
3586494	Impeller kit (cover plate with 6 screws)

MD6, MD7

22057107	Oil filter
21492771	Fuel filter, spin-on
21951342	Impeller kit (cover plate with 4 screws)
3586494	Impeller kit (cover plate with 6 screws)

MD3, MD17

22057107	Oil filter
23686345	Fuel filter, insert
829913	Fuel filter, spin-on
22222936	Impeller kit

2001, 2002, 2003, 2003T

22057107	Oil filter
829913	Fuel filter
838929	Engine zinc anode
21951342	Impeller kit (2001, 2002, 2003)
21951346	Impeller kit (2003T)

MD2010, MD2020, MD2030, MD2040

861473	Oil filter (MD2010/2020)
3840525	Oil filter (MD2030/2040)
861477	Fuel filter
3586494	Impeller kit ³⁾
22222936	Impeller kit (MD2030/2040) ⁴⁾

3) MD2010 SN -5101203008, MD2020 SN -5101309052

4) MD2010 SN 5101203009, MD2020 SN 5101309053

D1-13, D1-20

861473	Oil filter
861477	Fuel filter
22222936	Impeller kit

D1-30, D2-40

3840525	Oil filter
861477	Fuel filter
22222936	Impeller kit

D2-50, D2-55, D2-60, D2-75

3840525	Oil filter
861477	Fuel filter
21951346	Impeller kit

MD22, TMD22, TAMD22

861476	Oil filter, MD/TMD22A
3517857	Oil filter, MD/TMD/TAMD22B, C
21624740	Fuel filter
21951346	Impeller kit

MD30, TAMD30, TMD30, AQAD30

3517857	Oil filter
21492771	Fuel filter
838929	Engine zinc anode
21951356	Impeller kit
876069	Crankcase filter
876185	Air filter

MD31, TMD31, TAMD31, AQAD31, KAD32

3517857	Oil filter
21492771	Fuel filter
838929	Engine zinc anode (early models)
858488	Air filter (metal filter housing)
21646645	Air filter (plastic filter housing)
876185	Air filter, KAD32
21951356	Impeller kit
876069	Crankcase filter (SN - 2203116853)

D3 A-C (-MY2009)

8692305	Oil filter
31261191	Fuel filter
21646645	Air filter, round
21171277	Air filter, square
21951352	Impeller kit

D3 D-H (MY2010-)

30788490	Oil filter
21139810	Fuel filter
21379288	Air filter
21951352	Impeller kit

MD40, TMD40, TAMD40, AQD40, AQAD40

471034	Oil filter
21624740	Fuel filter
838929	Engine zinc anode
21951356	Impeller kit
21951360	Impeller (TAMD40, AQAD40)
876069	Crankcase filter
876185	Air filter

TMD41, TAMD41, AQD41, AQAD41

471034	Oil filter
21624740	Fuel filter
838929	Engine zinc anode (early models)
858488	Air filter (metal filter housing)
21646645	Air filter (plastic filter housing)
21951356	Impeller kit
876069	Crankcase filter (SN – 2204141572)

KAD/KAMD 42, 43, 44, 300

423135	Oil filter
21624740	Fuel filter
876185	Air filter
21951356	Impeller kit

D4, D6 A-F (-MY2019)

22030848	Oil filter
22030852	Oil filter, by-pass
21718912	Fuel filter
21702999	Air filter
838929	Anode, heat exchanger SN-407905
21868041	Anode, AQ exhaust pipe. Freshwater
21868042	Anode, AQ exhaust pipe. Brackish and saltwater
3584145	Crankcase ventilation filter
3588475	Impeller kit for D4 all inboard engines, D4 engines A-D with AQ/IPS drives
21951356	Impeller kit for D4 model E and F with AQ/IPS drives SN 2004033317-
3593573	Impeller kit for D6 all inboard engines, D6 engines A-D with AQ/IPS drives
22994993	Impeller kit for D6 model E and F with AQ/IPS drives SN 2006040970-

D4, D6 G (MY2020-)

22030848	Oil filter
22030852	Oil filter, by-pass
22984478	Fuel filter
21702999	Air filter
21868041	Anode, AQ exhaust pipe. Freshwater
21868042	Anode, AQ exhaust pipe. Brackish and saltwater
21951356	Impeller kit, D4
22994993	Impeller kit, D6



Replacement filter elements for Volvo Penta pre-fuel filter/water separator, see page 33.

**Puller screw**

The puller screw is the best way to remove the impeller from the sea water pump. It is very easy and there is no risk of damaging the pump housing.

Part no	Fits impeller
3843947	21951356
3843948	21951352
3843949	22994993

MAINTENANCE PARTS - GASOLINE ENGINES

V8-200/240/280, V8-300/350 (Gen 5), V8-380/430 (6.2L-Gen 5)

8692305	Oil filter
3847644	Fuel filter
21403633	Anode, manifolds
21700445	Impeller kit
22500000	Plug wires, V6
22500004	Plug wires, V8-300/350
23277051	Plug wires, V8-380/430 (6.2L)
22431179	Spark plugs, 6 pack (V6)
22431178	Spark plugs, 4 pack (V8)

V8-350/380/430 (6.0L)

8692305	Oil filter
3847644	Fuel filter
3858995	Anode, heat exchanger
21700445	Impeller kit
21801266	Plug wires
21772268	Spark plugs, 4 pack

V6-200/225 (Gen 1+)

8692305	Oil filter
3847644	Fuel filter
3858995	Anode, heat exchanger
22307636	Impeller kit
3888327	Plug wires
3859019	Distributor cap
3858977	Distributor rotor
21513423	Spark plugs, 6 pack

V8-225/270/300/320 (Gen 1+)

8692305	Oil filter
3847644	Fuel filter
3858995	Anode, heat exchanger
22307636	Impeller kit
3888328	Plug wires
3858975	Distributor cap
3858977	Distributor rotor
21467472	Spark plugs, 4 pack

3.0GLP-C/D/E/J

835440	Oil filter
21951348	Impeller, kit (C)
22307636	Impeller, kit (D/E/J)
3853799	Thermostat
3856537	Thermostat (o-ring)
3854260	Distributor cap
3854261	Distributor rotor
3888324	Plug wires
3586324	Drive belt (C)
3586325	Drive belt (D)
3860092	Drive belt (E)
3851857	Spark plugs

3.0GXJ-J, 3.0GXIC-J

835440	Oil filter spin on
22307636	Impeller kit
21148403	Thermostat
3856537	Thermostat (o-ring)
3854260	Distributor cap
3854261	Distributor rotor
3888324	Plug wires
21132392	Drive belt serpentine
3851857	Spark plugs

4.3GL-J/JF, GXI-J/JF, OSI-J/JF

8692305	Oil filter insert
3862228	Fuel filter, spin on (GL-J, JF)
3847644	Fuel filter, spin on (GXI, OSI)
22307636	Impeller kit
3831426	Thermostat kit fresh
3852111	Thermostat gasket fresh/raw
416033	Thermostat o-ring fresh
3587597	Thermostat raw
983944	Thermostat o-ring raw
3854331	Distributor cap (GL)
3854311	Distributor rotor (GL)
3859019	Distributor cap (GXI, OSI)
3858977	Distributor rotor (GXI, OSI)
3888325	Plug wires
21132390	Drive belt
21513423	Spark plugs 6 Pack

4.3GXJ-G/GF/OSI-G/GF

835440	Oil filter
3862228	Fuel filter
22307636	Impeller kit
3831426	Thermostat, kit (GF)
3587597	Thermostat (G)
983944	Thermostat, o-ring (G)
3852111	Thermostat, gasket (G, GF)
3859019	Distributor cap
3858977	Distributor rotor
3888327	Plug wires
3889124	Drive belt
21513423	Spark plugs

5.0GL-J/JF, GXI-J/JF, OSI-J/JF

8692305	Oil filter insert
3862228	Fuel filter, spin-on (GL)
3847644	Fuel filter, spin-on (GXI, OSI)
22307636	Impeller kit
983944	Thermostat o-ring raw
3852111	Thermostat gasket fresh/raw
3831426	Thermostat kit fresh/raw
3854548	Distributor cap
3862014	Distributor rotor
21132390	Drive belt
21467472	Spark plugs 4 pack

5.0GX-G/GX-GF/OSI-G/OSI-GF

835440	Oil filter
3862228	Fuel filter
21213664	Impeller kit
3831426	Thermostat, kit
3858975	Distributor cap
3858977	Distributor rotor
3889124	Drive belt
21467472	Spark plugs 4 pack

5.7Gi300-J/JF, 5.7OSI-J/JF, 5.7GX-J/JF, 5.7OSX-J/JF

8692305	Oil filter insert
3847644	Fuel filter, spin on
22307636	Impeller kit
3831426	Thermostat kit fresh/raw
3852111	Thermostat gasket fresh/raw
416033	Thermostat o-ring fresh
3587597	Thermostat raw
3858975	Distributor cap
3858977	Distributor rotor
21132390	Drive belt
21467472	Spark plugs 4 pack

5.7Gi-F/Gi-FF/GXi-G/GXi-GF/OSI-E/OSI-EF

835440	Oil filter
3862228	Fuel filter
22307636	Impeller kit
3831426	Thermostat, kit, fresh
3587597	Thermostat raw
3852111	Thermostat gasket fresh/raw
983944	Thermostat o-ring raw
3858975	Distributor cap
3858977	Distributor rotor
3889124	Drive belt
21467472	Spark plugs 4 pack

7.4GL

3850559	Oil filter
3862228	Fuel filter
3854286	Impeller (MD)
21951346	Impeller (HU, NC, LK)
3853983	Thermostat
3852071	Thermostat (seal ring)
3852111	Thermostat (gasket)
3851861	Spark plugs

7.4Gi, GSi, DPX385

3850559	Oil filter
3862228	Fuel filter
21951346	Impeller
3853983	Thermostat
3852071	Thermostat (seal ring)
3852111	Thermostat (gasket)
3851861	Spark plugs (Gi - MD-LK, GSi, DPX)
3851857	Spark plugs (Gi - BY-EF)

8.1Gi-J/JF/GXi-J/JF/OSI-J/JF

8692305	Oil filter
3847644	Fuel filter
22307636	impeller kit
3831426	Thermostat, kit, fresh
3852111	Thermostat gasket fresh/raw
3853983	Thermostat, raw
3852071	Thermostat (o-ring, small)
3861000	Thermostat (o-ring, large)
21132385	Drive belt
963699	Spark plugs

8.1Gi-H/HF, 8.1GX-G/GF, 8.1OSI-D/DF

835440	Oil filter
3862228	Fuel filter
22307636	impeller kit
3831426	Thermostat, kit, fresh
3853983	Thermostat, raw
3852071	Thermostat (o-ring, small)
3861000	Thermostat (o-ring, large)
21132390	Drive belt
3861326	Spark plugs

8.2GL

3850559	Oil filter
3862228	Fuel filter
3854286	impeller
3853983	Thermostat
3852071	Thermostat (o-ring)
3852111	Thermostat (gasket)
3851861	Spark plugs

8.2GSi, DPX415

3850559	Oil filter
3862228	Fuel filter
21951346	impeller (HU-BY)
21951348	impeller (WT)
3853983	Thermostat
3852071	Thermostat (seal ring)
3852111	Thermostat (gasket)
3851861	Spark plugs



Replacement filter elements for Volvo Penta pre-fuel filter/water separator, see page 35.

MAINTENANCE PARTS - GASOLINE ENGINES

AQ225, AQ255, AQ260, BB225, BB260, BB261	
835440	Oil filter
877765	Fuel filter
855686	Fuel filter, spin-on (BB225C, 261A)
3854286	Impeller kit (AQ225B/C, AQ255A)
21951346	Impeller kit (W=31 mm)
876120	Impeller kit (W=51 mm)
876305	Thermostat
3851861	Spark plugs, 4 pack

AQ231, AQ271, AQ280, AQ290, AQ311, BB231	
835440	Oil filter
877765	Fuel filter (AQ280, AQ290)
855686	Fuel filter, spin-on
21951346	Impeller kit (W=31 mm)
876120	Impeller kit (W=51 mm)
876305	Thermostat
3851861	Spark plugs, 4 pack

500, 501, 570, 571, 572, 740	
835440	Oil filter
855686	Fuel filter, spin-on
21951346	Impeller kit (W=31 mm)
876120	Impeller kit (W=51 mm)
876305	Thermostat
3851861	Spark plugs, 4 pack

AQ95, AQ100, AQ110, AQ115, AQ120A, AQ130 BB115	
3517857	Oil filter
22222936	Impeller kit
876080	Thermostat

AQ120B, AQ125, AQ131, AQ140, AQ145, AQ151, AQ171, 230, 250, 251 BB140, BB145	
3517857	Oil Filter
21951350	Impeller kit
875580	Thermostat
875820	Spark plugs, 4 pack

AQ165, AQ170 BB165, BB170	
3517857	Oil filter
21951350	Impeller kit
875791	Thermostat

MAINTENANCE PARTS - DRIVES

110S, 120S, MS25S, 130S, 150S	
22303438	Cover plate against hull
21389074	Rubber bellows kit

270	
876294	Drive joint bellows kit
875822	Seawater intake hose kit
876631	Exhaust bellows kit

280	
876294	Drive joint bellows kit
876633	Exhaust bellows kit
875822	Seawater intake hose kit

290, SP A-E	
876294	Drive joint bellows kit
876631	Exhaust bellows kit
876632	Seawater intake hose kit

280DP	
876294	Drive joint bellows kit
876631	Exhaust bellows kit
875822	Seawater intake hose kit

290DP, DP A-E	
876294	Drive joint bellows kit
876631	Exhaust bellows kit
876632	Seawater intake hose kit

DPG	
876294	Drive joint bellows kit
3860384	Exhaust bellows kit
876632	Seawater intake hose kit

DPX	
876294	Drive joint bellows kit
3860384	Exhaust bellows kit DPX-A
876631	Exhaust bellows kit DPX-S/S1/R
876632	Seawater intake hose kit

XDP	
21277185	Drive joint bellows kit
3885871	Exhaust bellows kit

SX, DP-S, DP-SM	
23075752	Drive joint bellows kit
3850426	Exhaust bellows kit

SX-A, DPS-A, DPS-B	
23075752	Drive joint bellows kit
3888916	Exhaust bellows kit

DPH, DPR	
3594509	Drive joint bellows kit
3588753	Exhaust bellows kit
21132674	Anti-barnacle bellows kit (steering cylinders)
3588767	Seawater intake hose kit

DPI	
3588753	Exhaust bellows kit
3594509	Drive joint bellows kit
23538670	Oil filter kit
3588767	Seawater intake hose kit

Volvo Penta IPS	
22057107	Oil filter, IPS1
22863663	Oil filter, IPS10
23005191	Oil filter, IPS15/2/20/3/30



Genuine Volvo Penta anodes are specially designed, manufactured and tested to ensure a perfect fit, ensuring reliable fastening and optimal anode protection for Volvo Penta drives and propellers.

Anodes for drives and propellers, see page 73.



Please note that products illustrated may differ from production models. Not all products listed are available in all markets, and standard equipment may vary between different markets. Every effort has been made to ensure that facts and figures are correct at the time of publication. Volvo Penta reserves the right to make changes to the statements and descriptions in the catalogue without prior notice at any time.

Please note that the illustrations in the catalogue are for information purposes only and should not be used for installation or workshop instruction purposes. In such case, reference should be made to the relevant technical publication. Illustrations and dimension sketches do not always fully agree with the actual products.

Products that are affected by EU legislation, RCD - Recreational Craft Directive, 2013/53/EU or EMC - Electromagnetic Compatibility Directive, 2014/30/EU, have been tested and approved according to the respective Directive.

Only products that fulfill the requirements of Recreational Craft Directive 2013/53/EU can be installed in new boats intended for sale in European markets.

This catalogue is also available on the Internet, at www.volvopenta.com